

# *MAX Bike*

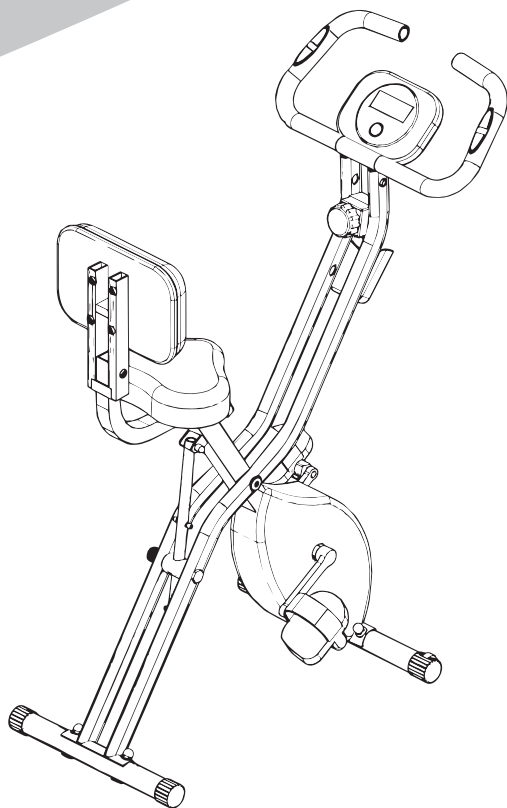

**User Manual**

---

**MAX-J02QB917G**

  
**maxcare<sup>®</sup>**



## COMPANY PROFILE

After two decades of experience in the health industry, **maxcare** founder utilized his knowledge and expertise in massage therapy from an Asian-Pacific perspective to establish our brand - **maxcare**. Our massage therapy business was expanded to Hong Kong in 2012 and is conferred 2017 Hong Kong Top Brand Award. Based in Hong Kong, we are specializing in design & innovation, manufacturing, and retailing of massage and healthcare products.

Believing in the value of 'Technology improves our quality of life' and 'Caring for your family', **maxcare** has been innovating highly qualified products with international patents. Besides, **maxcare** products fulfill various international safety standards, namely EU CE Mark, US UL/ETL Mark, Germany GS Mark, TUV certification, and China CCC Mark.

Motivated by our value, **maxcare** founder has been leading us to be one of the most competitive brands in Hong Kong health industry. **maxcare** applies the contemporary fashion design – neat and modern – on the mechanical engineering of massage chairs. To deliver our value and offer incredible massage experience and healthcare solution to the public, **maxcare** devotes to the innovation, design, manufacturing the top-notch family massage products. By integrating the company philosophy – Spirit Of Healthy Life - into our products, **maxcare** brings health to everyone.



Thank you for purchasing the Maxcare products. Before using the product, please read this manual thoroughly, particularly the Safety Precautions section, for the correct use of the product.

This manual should be well kept for easy reference. It enables you to perform a safe and efficient operation.

## CONTENT

---

Safety Precautions .....	P.01 - P.03
Name and Function of Components .....	P.04 - P.05
Product Installation .....	P.06 - P.09
Cleaning and Maintenance .....	P.10
FAQs and Solutions .....	P.10
Technical Specifications .....	P.11



## Safety Precautions



### 1. Important safety warning

- Please read this manual instruction carefully before operation.
- Don't use accessories which are not recommended.
- Any other usage that is not listed in this manual instruction is forbidden.
- Please don't use it if the cover or accessories is damaged.
- Please don't use it within one hour after having meal.
- Please don't adjust to the greatest intensity at the beginning of the training to avoid the risk of being injured.
- Don't abruptly start intense exercise on the machine, especially for those who don't work out often.
- If the power cord is damaged, don't attempt to change on your own. Please contact us for repair for safety reason.

#### **FORBIDDEN**

- It is forbidden to place heavy objects on top of the product.
- It is forbidden to let children use or play with the product.
- It is forbidden to sleep on the product.
- It is forbidden to use while drunk or sick.
- It is forbidden to put fingers or other foreign objects into the gaps, to prevent harm or malfunction.
- It is forbidden to operate the console with wet hands.
- People whose bodies are wet are forbidden to use this product.

#### **DISASSEMBLY FORBIDDEN**

- Do not disassemble the internal components of the product to avoid the potential damage.
- Anyone else, except maintenance personnel specified by our company, should not disassemble, maintain, or remodel this product. If any problem, please contact us immediately.



### 2. Environment for usage

#### **CAUTION**

- Please don't use it under high temperature and moist environment such as bathrooms.
- Please don't use it immediately while the environmental temperature changes sharply.
- Please don't use it under heavy-dusty or caustic environment.
- Please don't use it where there is not enough space or not good ventilation.
- Please don't use it when surrounding temperature is up to 40°C.
- Please don't use it when surrounding temperature is below 5°C. The lubricant can thicken quickly and increase the friction between parts.
- Don't use outdoor.
- Don't place it near fire or directly under the sun.
- Place the product on a flat surface.
- When moved from a low-temperature storage to a warm environment, the moisture inside the machine may affect, or damage, its functionality. Please rest the product within room temperature for 1 hour before use.



## Safety Precautions



### 3. People who have the below symptoms, please consult a doctor before use

- People who are receiving medical treatment, especially physically unfit, are not suitable to use this product.
- People who have cancers, acute illnesses, heart diseases, or severe high blood pressure, etc. are not suitable to use this product.
- Pregnant women or women that are in menses period are not suitable to use this product.
- People who are suffering from fever are not suitable to use this product.
- People who are suffering from heart diseases or carrying electronic medical equipment such as a heart pacemaker are not suitable to use this product.
- People who got injured or skin diseases are not suitable to use this product.
- People who have/ had back pain, or legs, waist, neck numbness/ injuries (disc herniation, spondylosis and cervical protrusion, etc. patients) are not suitable to use this product.
- People who have rheumatoid arthritis, rheumatism, gout are not suitable to use this product.
- People who have osteoporosis are not suitable to use this product.
- People who have respiratory difficulties are not suitable to use this product.
- People who have blood circulation problems such as thrombosis, severe aneurysm, or acute venous tumor, or infectious skin diseases are not suitable to use this product.
- People who have perception disorders due to diabetes are not suitable to use this product.
- People who have open wounds are not suitable to use this product.
- People who have spinal abnormalities or spine curvature disorders are not suitable to use this product.
- People whose health condition is poor are not suitable to use this product.
- People who aim for recovery are not suitable to use this product.



### 4. Safety

#### OPERATION INSTRUCTIONS CAUTION

- First position yourself on the seat and put both legs on the pedals before workout: please grip the handrail.
- Only one person at a time. The maximum loading capacity of the product is 150kg. Exceeding the limit could cause damage to the product or injury.
- Please make sure the product is correctly and firmly assembled every time before use to avoid accidents.
- This is a household item - not suitable for public use such as in schools or gyms.
- Please don't use it other than for training purpose.
- Please wear suitable clothing to avoid any clothing items being pulled into the machine.
- Please empty your pocket when using the product.
- Placing a protective layer or a floor mat underneath it can prevent damage.
- For safety reason, maintain a minimum of 0.5m between the product and others when use.
- Please don't treat it as a toy, guardians should pay extra attention.
- When folding and storing the product, please lock it tightly, especially when there are children around.



## Safety Precautions

- Hold the handle when both getting on and off the machine, keep your body balanced.
- Don't use other therapy devices while using this product.
- This product is not to be used for medical treatment purpose.
- It is possible to place a mat underneath the machine to avoid damage to the floor.
- Before use, check if the machine and its parts are damaged. If so, don't use it and contact us for repair.
- Don't ride on the handle, to avoid injury or malfunction.
- Stop using this product if there appears any irregularity, and please contact us immediately.
- Stop using this product if it causes discomfort, and please consult a doctor.
- This appliance is not intended for people (including children) with reduced physical, sensory or mental capabilities, or a lack of experience and knowledge, unless they are under supervision or instruction concerning the use of the appliance by a person responsible for their safety.
- Children should be supervised to ensure that they don't play with the appliance.
- This product is not designed for long-time use. Allow a 30-minute break (power off) for every one hour use. Long-time use could cause overheating and malfunction.
- Please plan workout routine according to own health condition and fitness. Inappropriate or excessive training could be harmful.
- Please allow enough space during use or assembly of the product, and that no one around would be hurt.



## 5. Maintenance

- This product should be maintained by us, users are prohibited to disassemble or maintain by themselves.
- Don't keep this product at a high temperature or near fire. Don't keep under direct sunlight.
- Please clean this product with dry cloths. Don't use thinner, benzene or alcohol.
- The mechanical components of this product are specially designed and made, it is not necessary to be specially maintained.
- Don't point sharp objects at this product.
- Don't roll or pull this product above uneven ground, it should be lifted before moving.
- Please use it intermittently; don't keep it continuously running for long.











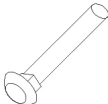

## 6. Solution of ordinary malfunctions

- If the meter can't work normally, please check the plug and socket if they are connected, and make sure the switch is turned on.

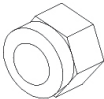
 Name and Function of Components

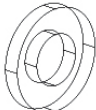
**Kit List**

 <p>Semi-round head screw (M6×12)</p>	 <p>Arc washer (M6)</p>	 <p>flat washer (M6)</p>	 <p>Arc washer (M8)</p>
 <p>Carriage bolts (M8×65)</p>	 <p>Cap nut (M8)</p>	 <p>Semi-round head screw (M8×35)</p>	 <p>M8 lock nut (M8)</p>
 <p>Semi-round head screw (M8×45)</p>	 <p>Spring washer (M8)</p>	 <p>flat washer (M8)</p>	 <p>Outer hexagonal spanner (13-15)</p>
 <p>Socket spanner (L5)</p>			

 Name and Function of Components

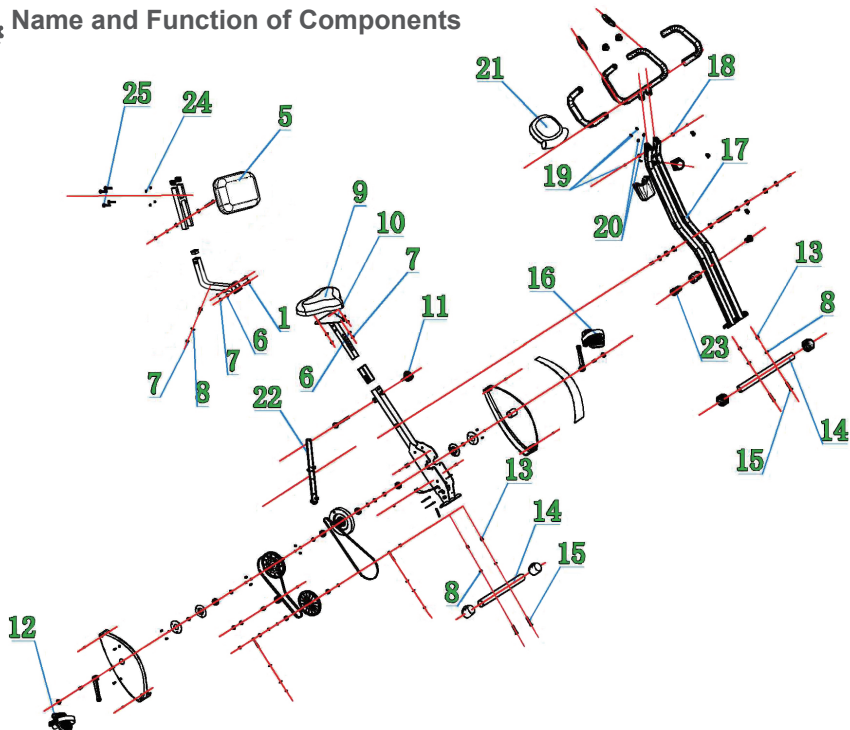







**Part List**

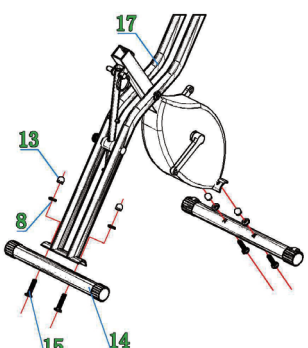

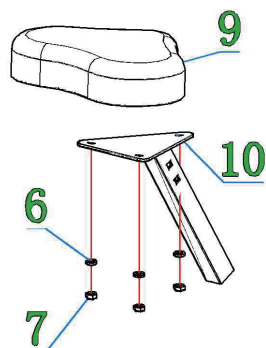

NO.	Name	QTY.	NO.	Name	QTY.	NO.	Name	QTY.
1	M8*45 carriage bolts	2	10	Seat holder	1	19	M6*12 Semi round head screw	4
2	Back stator	1	11	Adjustment Knob	1	20	Φ6.2 Arc screw	2
3	M8*40 Semi-round head screw	2	12	Pedal(right)	1	21	Handlebar	1
4	Back armrest	1	13	M8 Cap nut	4	22	Frame regulating lever	1
5	Back	1	14	Foot tube	2	23	Regulating rod fixed nut	2
6	Φ8.5 flat washer	5	15	M8*65 carriage screw	4	24	Spring gasket	4
7	M8 locknut	7	16	Pedal(left)	1	25	M8*45 carriage bolts	4
8	Φ8.5 Arc washer	6	17	Main frame	1			
9	Seat	1	18	Φ6.2 flat washer	2			



 Product Installation

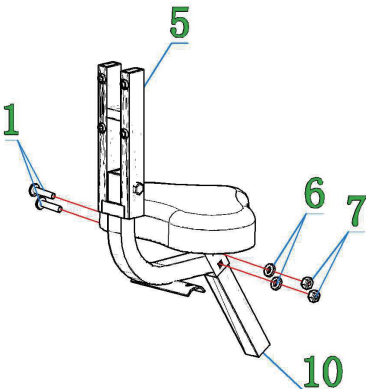

Installation Drawing				
	No.	Diagram	Part Name	QTY
	8		Arc washer (M8)	4
	13		Cap nut (M8)	4
	15		carriage bolt (M8×65)	4
<p>Step1 Align the hole of the foot tube (14) with that of the main frame (17), use the carriage bolts (15) , arc washers (8) and cap nuts (13) to fix the two parts together, and then tighten the nuts (13).</p>				
	No.	Diagram	Part Name	QTY
	6		Flat washer (M8)	3
	7		lock nut (M8)	3
<p>Step2 Align the hole of the seat (9) with that of the seat holder (10), place a M8 flat washer (6) on top and then tighten the lock nut (7).</p>				

 Product Installation

	No.	Diagram	Part Name	QTY
	6		flat washer (M8)	2
	7		Lock nut (M8)	2
	1		carriage bolt (M8x65)	2

Step3

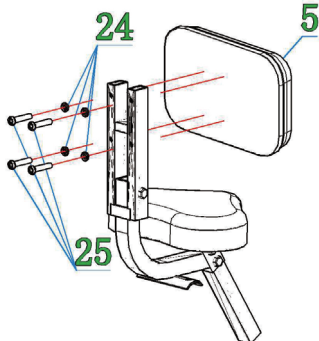

Align the hole of the back (5) and that of the seat holder (10), pass a M8\*45 carriage bolt (1) through them, place a M8 flat washer (6) on top, and then tighten the lock nut (7).

	No.	Diagram	Part Name	QTY
	24		Spring washer (M8)	4
	25		Semi-round head screw (M8x45)	4

Step4



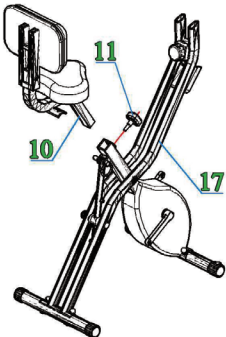

Attach the back (5) to the main frame (17) with the M8\*45 semi-round head screws (25) and spring washers (24). Tighten the screws.

 Product Installation

	No.	Diagram	Part Name	QTY
	11		Adjustment Knob	1

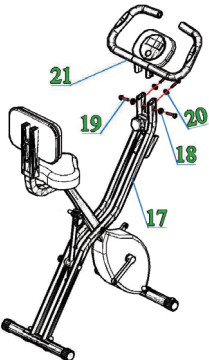
Step5

Insert the seat holder (10) into the main frame (17) as shown in the figure, fix it with the adjustment knob (11), which is used to adjust the height of the seat after installation.

	No.	Diagram	Part Name	QTY
	20		flat washer (M6)	2
	18		flat washer (M6)	2
	19		Semi-round head screw(M6*12)	4

Step 6

Insert the handlebar (21) into the main frame (17) as shown in the figure, gently adjust the position to align the holes on the side and back of the handlebar to those of the main frame. Use the M6\*12 semi-round head screws (19) and flat washers (18) for the side (do not tighten the screw); and use the M6\*12 semi-round head screws and flat washers (20) for the back (do not tighten the screw). Set right the position before tightening the 4 screws.

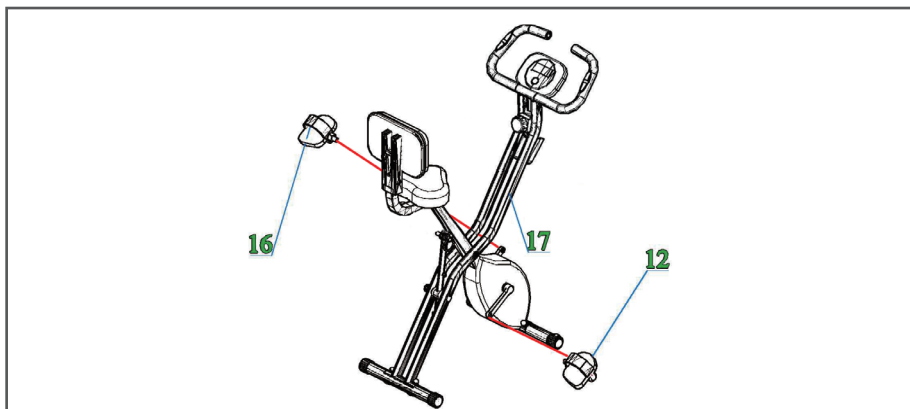
 Product Installation

## Step7

Please do not mix up the left and right pedals. And attach them correctly to the corresponding side of the main frame (there are labels on the pedals).



## Product Installation

### How to adjust the bike angles

The bike can be adjusted to 2 cycling positions or folded up for storage.

Upright cycling or recumbent cycling position or storage size:

Twist the round knob on the main unit to the left to loosen the bolt (do not fully remove). When stepping on the back foot of the exercise bike, lift the exercise bike and pull the round knob to adjust the angle. Before using the exercise bike, make sure that the safety lock is secured in place.



### How to use the LCD monitor

#### SPECIFICATIONS

- **TIME :** 0:00-99:59 MIN/SEC
- **SPEED :** 0:00-999.9 MPH
- **DISTANCE :** 0:00-999.9 MILES
- **CALORIES :** 0:00-999.9 KCAL
- **PULSE :** 40-240 BEATS/MIN



POWER ON/OFF



## Product Installation

### FUNCTIONS

- **POWER ON/OFF :** Press the button once or start to pedal to power on. The power will automatically switch off after 4 minutes of inactivity.
- **SCAN :** Press the button until the screen displays SCAN. The monitor will automatically scan each function: SPEED, TIME, DISTANCE, CALORIES and PULSE RATE, every 6 seconds. Press the button once to stay in a particular function. Press the button again once to move to the next function.
- **TIME :** Workout time is displayed in minutes and seconds. The monitor automatically counts from 0:00 to 99:59.
- **SPEED :** Workout speed is displayed in miles per hour.
- **DISTANCE :** Accumulated distance traveled with every use is displayed to a maximum of 999.9 miles.
- **CALORIES :** Calorie data is an estimate for an average user. It should be used only as a comparison between workouts in this unit.
- **PULSE :** Pulse data are more precise when two hands are on the handlebar grip sensors.
- **RESET :** Press and Hold the button for more than 2 seconds to reset all values to zero.

### Important Notes

- Before using the product, consult a doctor and get a body check-up. It is advised to get doctor's approval prior to any frequent and intense workout. In case of discomfort while using the product, stop immediately and consult a doctor. Correctly use this product as it is designed to be, read carefully this manual before workout.
- When unattended or idle, keep away children and pets.
- Before use: Plan workout routine based on body condition. Those who have not exercised for years, or are overweight, increase workout duration gradually – adding a few minutes every weekly is fine.



Warning

- Mindfully assemble the product, do not break

## Cleaning and Maintenance

### Cleaning

- Use a vacuum cleaner or soft cloth to clean the surface of the product and the surrounding area to extend its expected lifespan.
- Do not use corrosive cleaning agents like benzene or thinner to clean the product.

### Maintenance

- No additional maintenance is needed for this product.
- If the screen is not working or error, please check with the table below.
- Remove the batteries if you are not using the product for a long period of time.

## Errors & Solutions

Error Description	Solution
No display on screen or screen unresponsive	<ol style="list-style-type: none"> <li>1. Replace battery</li> <li>2. Check if batteries have been correctly put in</li> <li>3. Check if the connection cord is loose</li> </ol>
Unable to adjust resistance levels	Please contact us
Abnormal sounds	Please check if the screws of the handlebars and pedals are loose. If so, screw them tightly.

If the abnormal situations persist after taking the above solutions, please contact us.



## Technical Specifications

Product Name	: MAX Bike
Product Model	: MAX-J02QB917G
Batteries for the digital screen	: AAA*2
Product Gross Weight	: 22KGS
Product Net Weight	: 21KGS
Max. Loading Capacity	: 150KGS
Product Size - Stretched out 1 (L*W*H)	: 800mm*495mm*1050mm
Product Size - Stretched out 2 (L*W*H)	: 675mm*495mm*1190mm
Product Size - Folding (L*W*H)	: 349mm*495mm*1385mm
Meter Display	: Scan, Speed, Time, Distance, Calories, Pulse
Intensity Level	: 10 Level
Paddle Height	: 7



商標持有 : 美斯凱實業有限公司

客戶服務熱線 Customer Service Hotline :

香港 Hong Kong - (852) 2950-9383

中國 China - (86) 400 882-1883

[www.maxcare.net](http://www.maxcare.net)

[www.maxcareonlineshop.com](http://www.maxcareonlineshop.com)