

The logo consists of a stylized black shape resembling a speech bubble or a drop with a smaller circle inside it, positioned above the word 'maxcare' in a lowercase, sans-serif font.

Instruction

產品使用說明書

MAX-X04XQSR01

商標持有：美斯實業有限公司
Trademark holder: Maxcare Industrial Limited

客戶服務熱線Customer Service Hotline：
香港Hong Kong - (852) 2950-9383
中國 China - (86) 400 882-1883

www.maxcare.net
www.maxcareonlineshop.com

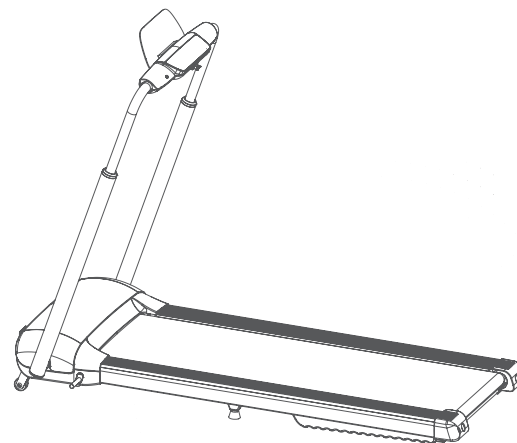



COMPANY PROFILE

After two decades of experience in the health industry, **maxcare** founder utilized his knowledge and expertise in massage therapy from an Asian-Pacific perspective to establish our brand - **maxcare**. Our massage therapy business was expanded to Hong Kong in 2012 and is conferred 2017 Hong Kong Top Brand Award. Based in Hong Kong, we are specializing in design & innovation, manufacturing, and retailing of massage and healthcare products.

Believing in the value of 'Technology improves our quality of life' and 'Caring for your family', **maxcare** has been innovating highly qualified products with international patents. Besides, **maxcare** products fulfill various international safety standards, namely EU CE Mark, US UL/ETL Mark, Germany GS Mark, TUV certification, and China CCC Mark.

Motivated by our value, **maxcare** founder has been leading us to be one of the most competitive brands in Hong Kong health industry. **maxcare** applies the contemporary fashion design – neat and modern – on the mechanical engineering of massage chairs. To deliver our value and offer incredible massage experience and healthcare solution to the public, **maxcare** devotes to the innovation, design, manufacturing the top-notch family massage products. By integrating the company philosophy – Spirit Of Healthy Life - into our products, **maxcare** brings health to everyone.



Thank you for purchasing the Maxcare products. Before using the product, please read this manual thoroughly, particularly the Safety Precautions section, for the correct use of the product.

This manual should be well kept for easy reference. It enables you to perform a safe and efficient operation.

CONTENT

Product Brief Introduction	P.21
Safety Instruction	P.22 - P.24
Parameters and Components	P.25
Installation Instruction	P.26-P.27
Exercise Suggestion and Guideline	P.28-P.29
Instruction for Use	P.30-P.34
Maintenance Guideline and Instruction	P.35-P.37

Product Brief Introduction

Product Name: CYBER RUN

Product Model: MAX-X04XQSR01

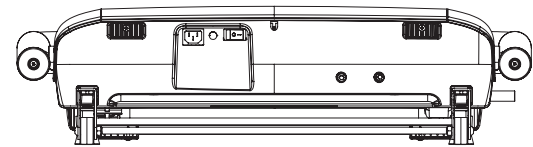
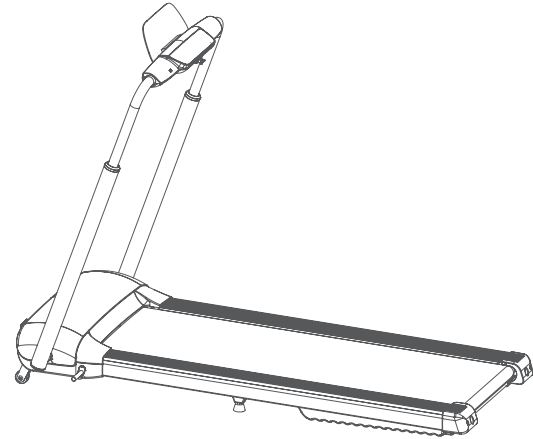

Safety Instruction

Thank you for choosing our product.

The correct use of treadmill is the guarantee for your safety and convenience.

Please read the following contents carefully before you use the treadmill.

Safety Instruction ①

1. Please make sure you have installed the treadmill correctly before powering it on. For an easy plugging in, be careful not to cover the socket on the wall when placing your treadmill please.
2. Please plug power cord into the socket connected to ground for safety. The plug of the treadmill is special, if the power cord got damaged, please contact our distributor or contact us directly.
3. Please unplug and lay power cord away when not using the treadmill.
4. Please do not take off protection cover casually. If you do need to open it for maintenance, please unplug the power cord first.
5. If it is the first time for you to use the treadmill, please do remember to grab the handrails till you feel comfortable.

Safety Instruction ②

1. Please warm up for 3-5 minutes, such as exercising joint and jogging before exercises.
2. Turn on switch at on the bottom to start the treadmill. Press "on/off" button, and digital display shows countdown "3,2,1" and then the treadmill begins to work. The system shall start at speed "1" automatically, so the beginner could take this speed to warm up.
3. Grab the front ends of the handrails by two hands, step onto the treadmill and press "+" to increase the speed to 1.5 to 3.0 slowly. Keep your body straight, relax as much as possible, and walk on the running belt. After you keep the pace, increase speed gradually; take off your hands from the handrails. Swing your arms along with your body to do steadily move warm-up and exercise.
4. After getting familiar with the treadmill functions, you can preset the exercise time and adjust it according to your own cadence.
5. On the digital display, you can choose to show speed, time, distance and calorie of your exercise.
6. Equipped with a 0.7-meter-long red magnetic safety key (the red one). If you find the treadmills abnormal or feel risky, please pull out this magnetic safety key to stop the treadmill instantly in order to avoid accident occurrence.

Safety Instruction

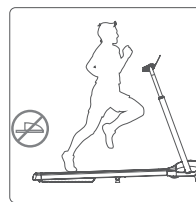

⚠ Do not wear too large or too loose clothes when doing exercise, in order to prevent accidents from your clothes hung to any parts of the treadmill. We recommend you to wear sneakers or gym shoes with rubber bottom.

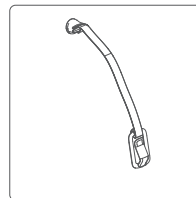

⚠ If the treadmill accelerates suddenly or increases its speed automatically caused by the problem of electronic console system, please pull out the safety key to stop the equipment instantly.

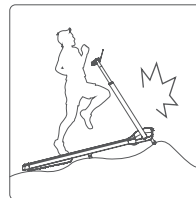

⚠ The treadmill is the indoor equipment, please do not use it outdoor. The place where to place the treadmill should be clean and flat. Please keep it away from moisture. Please do not put the treadmill on anything such as thick blanket which may influence the air circulation under the treadmill or influence balance of the user. The treadmill is special equipment, so please do not to use it for any other purpose.

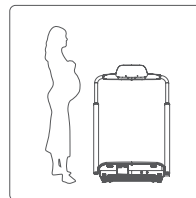

⚠ To avoid any risk, you should not allow children or pregnant woman close to the treadmill when it is on.

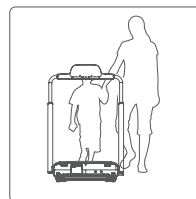

⚠ There should be adult accompanying when children use the treadmill.

Safety Instruction

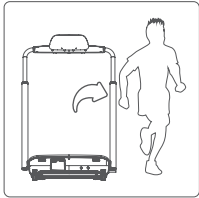

⚠ If you feel dangerous during exercise, you should use the front handrail to help you jump off to the ground.

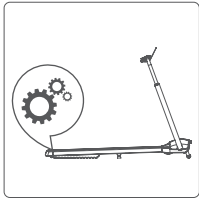

⚠ Don't stand on the rear cover, to prevent incident.

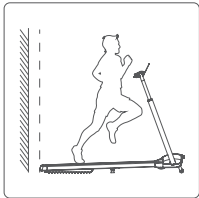

⚠ There must be a safe area (2meter * 1meter) behind the treadmill.

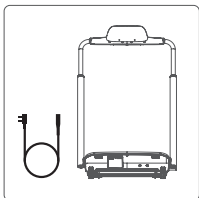

⚠ When the treadmill is not in use, unplug the power cord to avoid misuse.

Hints:

1. Beginners shall get familiar with the PROG. buttons on the console before using the treadmill.
2. To prevent falling down, please stand on the plastic anti-skid plates on both sides first when starting the treadmill instead of standing on the running belt directly.
3. Before running, please put on your sportswear instead of jeans or leather shoes.
4. Please do not play with other people while using the treadmill. It is strictly forbidden to jump off the treadmill during the running process.

Parameters and Components

Product name	CYBER RUN
Product model	MAX-X04XQSR01
Unfolding size (L*W*H)	1490*770*1182mm
Speed	1-12Km/h
Rated voltage	220V-240V
Rated frequency	50/60Hz
Rated power	560W
Efficient running area	420*1200mm
Display	LED
Gross weight	44KG
Net weight	36KG
Max user weight	100KG
Packaging size	1570mm(L) X 830mm(W) X 230(H)
Category and level	HB
App Connectivity	✕
Safety protection	1. Safety switch on the console 2. Overload protector fuse on the treadmill's internal system

We reserve the rights to improve or change the pictures and technology parameters of this product without prior notice. Please understand.

Component List

No.	Name	Qty	Remarks
1	Entire machine (base, main frame and electric console)	1pc	
2	Spare parts box	1box	Safety key 1pc Hexagon wrench 1pc Lubricating silicone oil 1 bottle User manual 1pc Power cord 1pc phone paste holder 1pc

Installation Instruction

1. Open the package; take out the treadmill and spare parts box, including (power cord, safety key and user manual) from the box.

spare parts
box

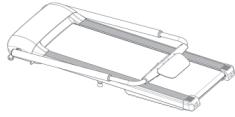

2. How to unfold the treadmill?

2.1 Raise the uprights, and then shake them until they are locked in place without falling down.

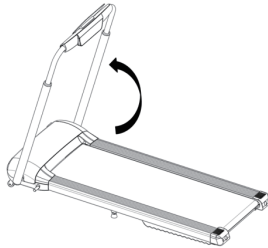

3. How to fold the treadmill?

3.1 Step on the foot pedal on the bottom left as the below image to unlock the uprights, and then push forward the uprights until the uprights begin to fall down automatically and finally lay flat.

Note: If the foot pedal is stuck, please shake the uprights back and forth and try to unlock again. This case is caused by the locking mechanic system, not a quality problem.

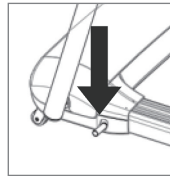

Installation Instruction

3.2 To keep the treadmill upright: Please hold the transverse tubule as shown in image 1 until the treadmill become completely against the wall as shown in below picture.

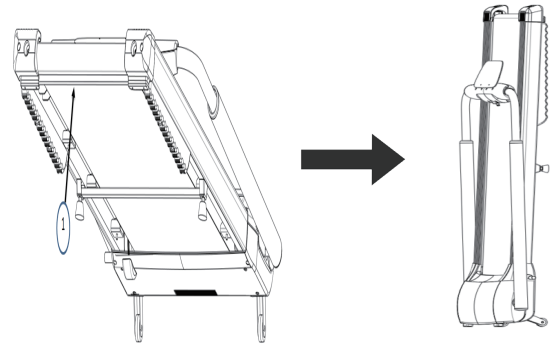

4. Footpads in the middle is adjustable to ensure the treadmill is stable on different surfaces. Screw down the nut above footpad tightly after finish adjusting the height.

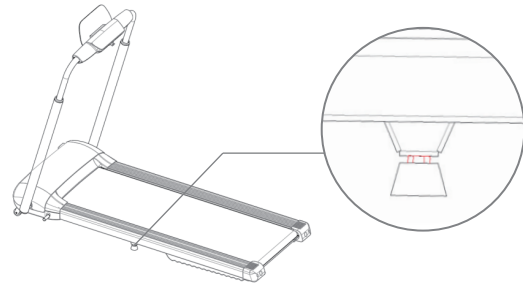

Exercise Suggestion and Guideline

If it is your first time to use motorized running machine, you need to read the below tips:

Preparation

Before exercise, it is better to know your own health status in order to make an exercise plan based on it. It is recommended to consult a doctor or a professional to get multiplier effects.

Before first use of the running machine, please stand by it and learn how to control it, for example: start, stop, adjust speed and etc. After getting familiar with it, you can start to use the running machine. Stand on the plastic anti-slip plates on the two sides of the track and seize the handrails by two hands. Then, turn on the running machine and adjust the speed around 1.6~3.2km/h (low speed). Keep your body straight and your eyes look forward. Step on the running belt carefully and relax yourself until you can gradually follow the speed. When you are comfortable, you may slowly increase the speed to 3~5km/h. Keep this speed for about 10 minutes, and then slow down it until it stops. For your first time, please do not run at high speed to prevent from falling down.

Exercise

Walk about 1 km at a fixed pace and record the time it spent. It may take 15-25 minutes. When the speed is at 4.8 km / h, it shall take you about 12 minutes for a distance of 1 km. After you can easily do it for a few times, you can gradually increase the speed. Keep it for 30 minutes, and you can get a good exercise. Before you start to walk, please be patient and be aware that this exercise is good for your health during the whole life time.

The Frequency of Exercise

Your target is to exercise 3-5 times every week, and each time exercise for 15-60 minutes. It is better to make an exercise schedule based on your body status, rather than do it according to your own preferences. You can control the intensity by adjusting the speed and exercise time.

Exercise Time

Shortcut: 15-20 minute exercise is a good way to save time. Warm up for 5 minutes at 4-4.8 km / h, and then increase speed by 0.3 km / h increment per minute until you feel at a suitable speed, and keep running for about 45 minutes. You will fully enjoy this exercise.

The above content is for reference only. Please consult professionals for more details.

Wearing

The only thing you need is just a pair of good shoes, and we recommend you to wear running shoes or gym shoes during exercise. Meanwhile, please be careful that there is nothing stuck on the shoes in order to avoid from anything dropping into running machine and then damaging the running plate and belt. Clothes should be comfortable and suitable for sports, and we recommend you to wear the breathable sportswear made from cotton.

Exercise Suggestion and Guideline

Stretch exercise

No matter how fast you walk, it is better to do stretch exercises first. Warm muscle is easier to stretch, so please spend 5-10 minute to warm up first. Then stop and use the below methods to do stretch exercises. Stretch for 5 times and at least 10 seconds for each leg in warm-up, and do it again after exercise.

1. Stretch down

Keep your knees slightly curved, and slowly bend your body forward. Relax your back and shoulder and touch your toes with your hands (see figure 1). Keep this for 10-15 seconds, and then relax. Repeat it for 3 times.

2. Foot tendon stretch

Sit on a clean cushion, stretch one leg out and adduct another leg to cling the inner side of the leg stretched-out, and then touch the toes by hand (see figure 2). Keep this gesture for 10-15 seconds and then relax. Repeat this 3 times for each leg.

3. Foot and heel tendon stretch

Stand with your hands on the wall or tree, and separate your two legs forward and back. Lean toward the wall or tree, and keep the back leg straight and put its heel to floor (see figure 3). Keep this gesture for 10-15 seconds and then relax. Repeat this 3 times for each leg.

4. Quadriceps stretch

Hold wall or table by your left hand for balancing, extend your right hand backward to grasp your right ankle, slowly pull the heel toward your butt until you feel tightness of the front muscle on your thigh (see figure 4). Keep this gesture for 10-15 seconds and then relax. Repeat this 3 times for each leg.

5. Sartorius muscle (inner muscle of thigh) stretch

Sit down with two soles facing each other and two knees outwards. Grasp the two feet and pull them towards your groin. Keep this gesture for 10-15 seconds, and then relax. Repeat this 3 times.

Exercise safety measures

Please consult a professional before exercise. He can give you some suggestions about exercise frequency, intensity and duration according to your age and physical condition. During exercise, if you feel chest choking or chest pain, irregular heartbeat, breath difficulty, dizziness or any other discomfort, please stop immediately. And consult professionals before you resume the exercise.

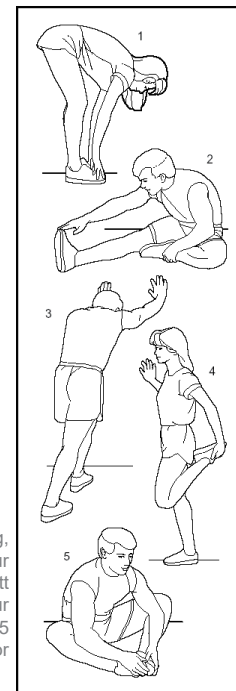

Instruction for Use

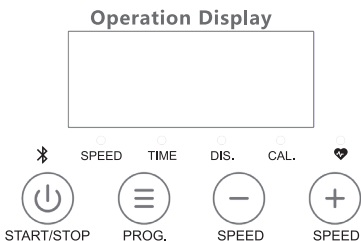

Button and Function

1. On/off: Press the button to start or stop the treadmill
2. PROG. Button:
Choose from three preset modes (Time reciprocal, distance reciprocal and calorie reciprocal),
Or 3 fixed programs (P1,P2,P3) in standby status.
Switch speed/time/distance/calorie and heart rate in running process.
Note: Heart rate can be switched and recorded when your hand is over the sensor.
3. Plus: Increase the value of selected item including speed, time, distance and calorie
4. Minus: Decrease the value of selected item including speed, time, distance and calorie

Mode

1. Time Reciprocal
 - 1.1 Press PROG. switch button once to enter into time reciprocal mode when treadmill is standby, time indicator light will flash and "30:00" will be shown on the operation display.
Then press "+" or "-" to set time period from 5:00 (at minimum) to 99:00 (at maximum) .
 - 1.2 Treadmill will start with min speed after complete the adjustment.
Press "+" or "-" again to set speed,
Current speed/time/distance/calorie data will be respectively shown on operation display by switching function switch button. Treadmill will stop when time shows "0:00".
2. Distance Reciprocal
 - 2.1 Press PROG. switch button twice to enter into distance reciprocal mode when treadmill is standby, distance indicator light will flash and "5.0" will be shown on the operation display.
Then press "+" or "-" to set distance from 0.5km (at minimum) to 99km (at maximum) .

Instruction for Use

3. Calorie Reciprocal
 - 3.1 Press program switch button three times to enter into calorie reciprocal mode when treadmill is standby, calorie indicator light will flash and "100" will be shown on the operation display.
Then press speed increase/decrease button to adjust calorie, it arranges from 20 kcal (at minimum) to 990 kcal (at maximum) .
 - 3.2 Treadmill will start with a min speed after complete adjustment on time.
Press "+" or "-" to again to adjust speed,
Current speed and left time/distance/calorie data will be respectively shown on operation display by switching function switch button.
Treadmill will stop when distance and calorie show "0:00".

4.Fixed Program P1

- 4.1. Press PROG. button four times to choose P1 strolling program when treadmill is standby.
Press "+" or "-" to adjust running time after P2 display 3 seconds and "30:00" flashes on the operation display
Then press "+" or "-" to set time.
Treadmill will start after complete adjustment.
Time window shows time reciprocal, distance window shows running distance, calorie window shows calorie to be consumed, and speed window shows the speed in each segment.
Altogether 10 segments for this mode,
You can set the speed for each segment while the time is fixed.

4.2 Treadmill stops working when time window shows "0:00"

Segment	1	2	3	4	5	6	7	8	9	10
Speed										
km/h	2	1	4	4	2	4	4	3	2	1

5.Fixed Program P2

- 5.1 Press PROG. button five times to choose P2 jogging program when treadmill is standby. Press "+" or "-" to adjust running time after P2 display 3 seconds and "30:00" flashes on the operation display
Then press "+" or "-" to set time. Treadmill will start after complete adjustment.
Time window shows time reciprocal, distance window shows running distance, calorie window shows calorie to be consumed, and speed window shows the speed in each segment.
Altogether 10 segments for this mode,
You can set the speed for each segment while the time is fixed.

5.2 Treadmill stops working when time window shows "0:00"

Segment	1	2	3	4	5	6	7	8	9	10
Speed										
km/h	3	4	6	4	6	6	6	4	6	1



Instruction for Use

6Fixed Program P3

6.1 Press PROG. switch button six times to choose P3 running program when treadmill is standby.

Press "+"or "-" to adjust running time after P3 display 3 seconds and "30:00" flashes on the operation display

Then press "+"or "-" to set time.

Treadmill will start after complete adjustment.

Time window shows time reciprocal, distance window shows running distance, calorie window shows calorie to be consumed, and speed window shows the speed in each segment.

Altogether 10 segments for this mode,

You can set the speed for each segment while the time is fixed.

6.2 Treadmill stops working when time window shows"0:00"

Segment	1	2	3	4	5	6	7	8	9	10
Speed										
km/h	5	4	8	8	6	8	6	8	4	1

Photoelectric Heart Rate Monitoring

Put your hand over the sensor on the left of operation display when treadmill is standby or at work,

Value on the operation display will automatically switch into your current heart rate.

Notes:

The heart rate data will be different by the different way you hold the handrail.

The data is only for reference, not medical basis.

More details,please see appendix



Instruction for Use

7Error information of control device and troubleshooting methods

1. Information Code: Er 1, Safety key disconnected

1.1 Check whether the safety key is connected to the designated position.

1.2 Check whether the safety key is loosen or dropped

1.3 Check or replace the safety key

1.4 Check or replace the console

1.5Check or replace the controller circuit board

2. Information Code: Er 7, Problem on the motor near motor

2.1 Check if the motor cable is loosened or dropped.

2.2 Check or replace the motor.

2.3 Check or replace the controller

3. Information Code: Er 8, No signal error

3.1 Check if the connecting cable is loosen, dropped or damaged

3.2 Check or replace the console

3.3 Check or replace the controller

4. Information Code: Er 9, Overload protection

4.1 Check if overloaded

4.2 Check if the mechanical running parts are jammed

4.3Check if there is a lack of lubricant oil. When lack of lubricant oil, the friction between plate and belt would increase

4.4 Check if the running plate is badly worn

4.5 Check if the running belt is badly worn

4.6 Check if the motor is short-circuited

4.7 Check or replace the controller

4.8 Check or replace the motor

5. Information Code: Er 10, Overvoltage/Undervoltage protection

5.1 Please check if the voltage on the power is normal: AC 220-240V

5.2 Check or replace the controller

5.3 Check or replace the motor

6.Information Code: Er 11,Over current protection

6.1 Check if overloaded

6.2 Check if the mechanical running parts are jammed

6.3 Check if there is a lack of lubricant oil. When lack of lubricant oil, the friction between plate and belt would increase

6.4 Check if the running plate is badly worn

6.5 Check if the running belt is badly worn

6.6 Check if the motor is severely short-circuited

6.7 Check or replace the controller

6.8 Check or replace the motor

Instruction for Use

7.Information Code: Er 12, electric motor short circuit

7.1 Check whether there is any foreign bodies at the output end of the controller causing short circuit

7.2 Check or replace the motor

8. Some or all of the buttons are not working well

8.1 Uncover the upper case of the electric meter and test if the buttons work well

8.2 Check or replace the electric meter board

8.3 Disconnect power supply, re-plug and then check if the buttons work well

9.No display on console

9.1 Check if the voltage on the power is normal: AC 220-240V

9.2 Check if the switch is on

9.3 Check if the fuse of plug socket is damaged. Replace if so.

9.4 Check controller and the LED

9.5 Check all connecting cable

9.6 Check or replace the electric meter board

9.7 Check or replace the near motor controller circuit board

Maintenance Guideline and Instruction

1. Guideline

WARNING: Be sure that the motorized treadmill is not plugged in when you clean or maintain the product.

Cleaning: A comprehensive cleaning shall significantly extend the product life.

Remove dust regularly to keep parts clean. It is necessary to clean the exposed parts on two sides out of the belt, and this shall decrease dust accumulation under the belt. Be sure your sports shoes are clean before exercise and this could avoid lint from dropping into the running machine and then damaging the running plate and belt. Scrub the belt surface by a wet cloth with soap, and be careful not to spill water on the electrical components or under the belt.

WARNING: Be sure that the motorized treadmill is not plugged in before remove the motor cover.

It is necessary to clean the motor and lubricate with silicone oil at least once a year.

The treadmill has been pre-coated with silicone oil between the running plate and belt. It is necessary to lubricate it by silicone oil regularly, because the friction between the running belt and plate has big impact on product life and performance. We recommend you to take regular inspection on the running plate. If the running plate is damaged, please contact our customer service center.

We recommend the user to squeeze drops of the silicone oil between running belt and plate according to the following timetable:

Low frequency users (use time: less than 3 hours per week): add silicone oil once every 6 months

Middle frequency users (use time: 3-5 hours per week): add silicone oil once every 3 months

High frequency users (use time: more than 5 hours per week): add silicone oil once every 1.5 months

We recommend you buy silicone oil from your local distributor or contact us directly.

2. Instruction

In order to maintain your running machine better to extend product life, it is recommended to turn off the running machine after using it for 2 hours, and have a 10 min break before continue.

If the running belt is too loose, it could be slippery when you exercise; if too tight, it may decrease the motor performance and increase the abrasion of drum and running belt. You can check whether the running belt is fitting or not by raising the two sides of running belt horizontally by hands. The suitable distance between raised running belt and plate is 50-75mm.

2.1 Running plate lubrication

1. We mentioned above that it is necessary to add silicone oil on running plate at the right time. But please do not use excessive silicone oil. Remember: proper lubrication is an important factor in extending the product life of a treadmill.

2. The method to check whether it is necessary to add silicone oil

Raise the running belt and stretch your hand as far as possible to touch the central part of the back side of the running belt. If your hands can grab a little silicone oil (feel slightly moist), that means you do not need to inject silicone oil. If the running plate is dry and no silicone oil adhered to your hand, then you need to inject silicone oil.

Maintenance Guideline and Instruction

3. The procedure to squeeze silicone oil on the running plate:

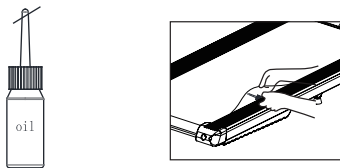

Note: The cut is about 5 mm

a) As shown in the picture, cut the oil bottle pipe, twist off the cover, tear the inner sealing paper, and then tighten the cover.
 b) When the running machine is stop working, squeeze the oil bottle slowly to let the oil flow into the running belt through the oil pipe, and run the treadmill at a speed of 1km/h to evenly apply the silicone oil, and lightly tap on the belt in the middle. In a few minutes, the silicone oil can be completely absorbed by the running belt.

2.2 Tautness adjustment of the running belt.

The running belt has been adjusted to a suitable tautness twice after the installation and before delivery. However, after use for a period of time, the running belt could be somehow loose. For example: the user may feel standstill or slippery during his running. When this phenomenon occurs, please adjust the tautness of the running belt by rotating the both left and right adjusting bolts clockwise with a half circle as a unit. (to tighten the running belt, please operate in an anticlockwise direction). If the running belt is too loose, the user will feel slippery when running; while it is also not good if the running belt is too tight, because it shall increase the motor load and damage the motor, running belt, the roller and etc.

2.3 The belt centering

1. Place the running machine on even ground.
2. Start the running machine and set the speed at about 3.5 kilometers per hour.
3. If the running belt is tilted to the left side, rotate the adjustment bolt on the left side by 1/2 circle in the clockwise direction, and then rotate the adjustment bolt on the right side by 1/2 circle in an anticlockwise direction.
4. If the running belt is tilted to the right side, rotate the adjustment bolt on the right side by 1/2 circle in the clockwise direction, and then rotate the adjustment bolt on the left side by 1/2 circle in an anticlockwise direction.

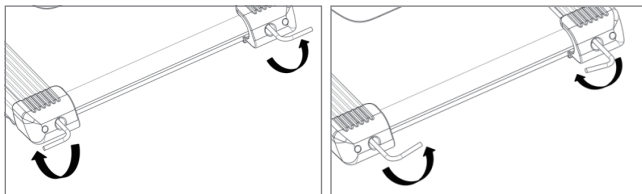

If the running belt is tilted to the left side, rotate the adjusting bolt as image

If the running belt is tilted to the right side, rotate the adjusting bolt as image

Maintenance Guideline and Instruction

2.4 Driving belt adjustment

The driving belt has to be adjusted before delivery. However, after using a period of time, slipping phenomenon may occur and the user can adjust the driving belt by itself.

Adjustment procedure (as shown in the right picture):

- ① Rotate the adjustment bolt clockwise with a wrench
- ② The adjustment range: take load without slipping as the standard

Note: please clean junk in the belt groove and pulley groove regular

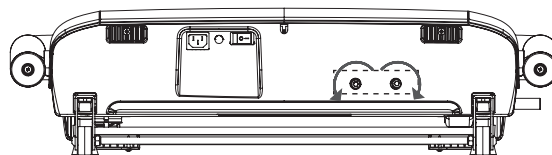

Please contact your local distributors for service.