



User Manual
MAX-76A100



maxcare[®]



COMPANY PROFILE

After two decades of experience in the health industry, **maxcare** founder utilized his knowledge and expertise in massage therapy from an Asian-Pacific perspective to establish our brand - **maxcare**. Our massage therapy business was expanded to Hong Kong in 2012 and is conferred 2017 Hong Kong Top Brand Award. Based in Hong Kong, we are specializing in design & innovation, manufacturing, and retailing of massage and healthcare products.

Believing in the value of 'Technology improves our quality of life' and 'Caring for your family', **maxcare** has been innovating highly qualified products with international patents. Besides, **maxcare** products fulfill various international safety standards, namely EU CE Mark, US UL/ETL Mark, Germany GS Mark, TUV certification, and China CCC Mark.

Motivated by our value, **maxcare** founder has been leading us to be one of the most competitive brands in Hong Kong health industry. **maxcare** applies the contemporary fashion design – neat and modern – on the mechanical engineering of massage chairs. To deliver our value and offer incredible massage experience and healthcare solution to the public, **maxcare** devotes to the innovation, design, manufacturing the top-notch family massage products. By integrating the company philosophy – Spirit Of Healthy Life - into our products, **maxcare** brings health to everyone.



Thank you for purchasing the Maxcare products. Before using the product, please read this manual thoroughly, particularly the Safety Precautions section, for the correct use of the product.

This manual should be well kept for easy reference. It enables you to perform a safe and efficient operation.

CONTENT

Safety Precautions	P.01 - P.04
Name and Function of Components	P.05 - P.06
Control Interface	P.07
How to Use	P.08 - P.26
Cleaning and Maintenance	P.26 - P.27
FAQs and Solutions	P.28
Technical Specifications	P.28



Safety Precautions



1. Important safety warning

- Keep children and pets away from the movable parts of this product for the avoidance of accidents caused by the up-and down-ward movement of the calf rest and back cover.
- When in use, sliding or transporting, please ensure that there are no people or pets nearby (the back, bottom, front and sides of the product), and that no foreign objects or pets inside the product, to avoid accidents.
- Please use well-grounding power supply suited to this product.
- Please pull out the plug after use or before cleaning to avoid injury or damage to the product.
- Do not use unauthorized accessories.
- Don't use this product outdoors.
- Please read this manual instruction carefully before operation.
- Any other usage that is not listed in this manual instruction is forbidden.
- Recommended usage time of this product is 20 minutes/ session.
- Please check if any part of this products is damaged before use. If so, please do not use it and contact us for repair.
- Please do not use it if the cover is broken or damaged.
- Please do not use it if the shell or surface is damaged.
- Please do not drop anything into this product.
- Please do not fall asleep while using this product.
- Please do not use it if drunk or feeling unwell.
- Please do not use it within one hour after having meal.
- Please do not adjust to the maximum intensity at the beginning of the massage to avoid the risk of being injured.
- Please do not keep sharp objects in pockets when use.
- Keep the plug clean from needles, rubbish or water.
- If the power cord is damaged, do not attempt to change on your own. Please contact us for repair for safety reasons.



2. Environment for usage

- Please do not use it in a moist environment such as bathrooms.
- Please do not use it when there is a drastic change in temperature.
- Please do not use it under heavy-dusty or caustic environment.
- Please do not use it where there is not enough space or not good ventilation.
- Please switch off the power and unplug the machine after use.
- Please do not use it when surrounding temperature is up to 40°C.
- Please do not use it when surrounding temperature is below 5°C. The lubricant can thicken quickly and increase the friction between parts.
- Turn off and pull out the plug during thunderstorms.
- Place the product on a flat surface.
- Do not use outdoors.
- Do not place it near fire or directly under the sun.
- When moved from a low-temperature storage to a warm environment, the moisture inside the machine may affect, or damage, its functionality. Please rest the product within room temperature for 1 hour before use.



3. People who have the below symptoms, please consult a doctor before use

- People who are suffering from osteoporosis.
- People who are suffering from heart disease or carrying electronic medical equipment such as heart pacemaker.
- People who have a fever.
- Pregnant women or women that are in menses period.
- People who got injured or skin diseases.
- Children under the age of 14 or people mentally unbalanced without being supervised are not allowed to use this machine.
- People who are told by the doctor to have rest or people who feel unwell.
- People whose bodies are wet are forbidden to use this product.



Safety Precautions

- The appliance has heating function. People who are insensitive to heat must be careful when using the appliance.
- People who are receiving medical treatment, especially those who are physically unfit.
- People who have open wounds.
- People who aim for recovery.



4. Safety

- Please do not place heavy objects on this product.
- Do not use other therapy devices while using this product.
- This product is not to be used for medical treatment purpose.
- Only one person at a time.
- Recommended usage time of this product is 20 minutes/ session.
- It is possible to place a mat underneath the machine to avoid damage to the floor.
- Check if the voltage is suitable to the specification of this product.
- Do not use wet hands to pull the plug.
- Do not allow water to get into the product, for the avoidance of electric shock or damage to this product.
- Do not pull or drag the power cord when unplugging. Please be gentle.
- Do not damage the wires or change the circuit of this product.
- Do not use wet cloths to clean the electric parts such as the switch and plug.
- Be away from this product during power cut to prevent injury in case power resumes suddenly.
- Stop using this product if there appears any irregularity, and please contact us immediately.
- Stop using this product if it causes discomfort, and please consult a doctor.
- This appliance is not intended for people (including children) with reduced physical, sensory or mental capabilities, or a lack of experience and knowledge, unless they are under supervision or instruction concerning the use of the appliance by a person responsible for their safety.
- Children should be supervised to ensure that they do not play with the appliance.
- If the power cord is damaged, it must be replaced by us in order to avoid a hazard.
- Do not ride on the handle to avoid injury or malfunction.
- Keep the power cord away from hot or moving objects.
- Please cut off power and pull out plug before moving.
- If the product is found damaged, broken, suffering from power leakage, or with exposed parts, please stop using it.



5. Maintenance

- This product should be maintained by us, users are prohibited to disassemble or maintain by themselves.
- Please always turn off the main power after use.
- Do not use this product if the socket is loose.
- If this product is to be left idle for long, please tie up the power cords and keep it in dry and dustless environment.
- Do not keep this product at a high temperature or near fire. Do not keep under direct sunlight.
- Please clean this product with dry cloths. Do not use thinner, benzene or alcohol.
- The mechanical components of this product are specially designed and made, no special maintenance required.
- Do not point sharp objects at this product.
- Do not roll or pull this product above uneven ground, it should be lifted before moving.
- Please use it intermittently; do not keep it continuously running for long.



6. Solution of ordinary malfunctions

- It is normal if the motor makes noises during operation.
- If the remote control can't work normally, please check the plug and socket if they are connected, and make sure the switch is turned on.
- If the rated working time is over, the power will automatically go off. If this product works continuously for too long, the temperature control will automatically turn off the machine, if so, please allow a 30-minute break before resuming.

 **Safety Warning**

 **Warning**

When the calf rest is ascending during use, do not apply pressure on it. This is to prevent the massage chair from falling forward and causing damage or injury.

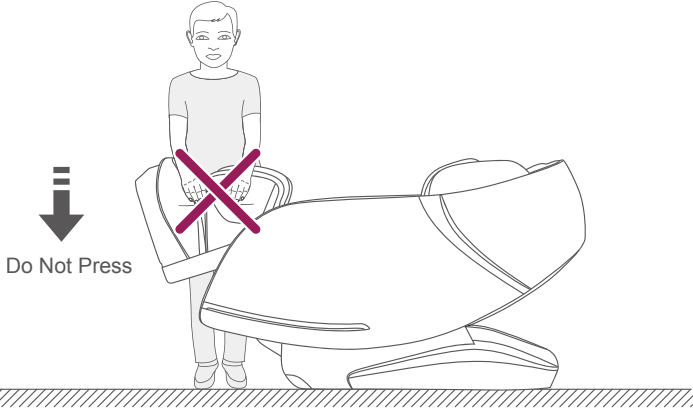

 **Warning**

Prior to sitting on the massage chair, please make sure the mechanical massage hands are not located under the seat. This is to avoid the discomfort caused to the hip area when sitting and the possible damage to the massage hands.

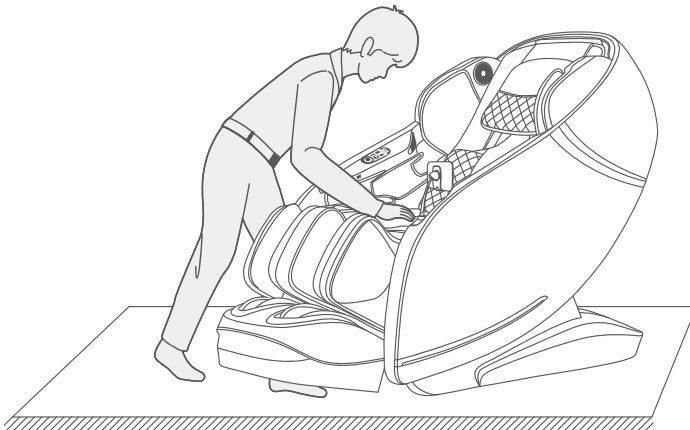

 **Safety Warning** **Warning**

In “standby” mode, or when the massage chair has been connected to power, do not drag/ pull the power cord. Damage to the power plug (or its parts) due to forceful pulling/ dragging will cause damage to the product or possible electric shock. It is advised to unplug the massage chair and tie up the power cord when not in use.

The touch screen monitor holder is fixed. Do not pull the holder with too much force when using or moving the massage chair, to avoid damaging the chair.

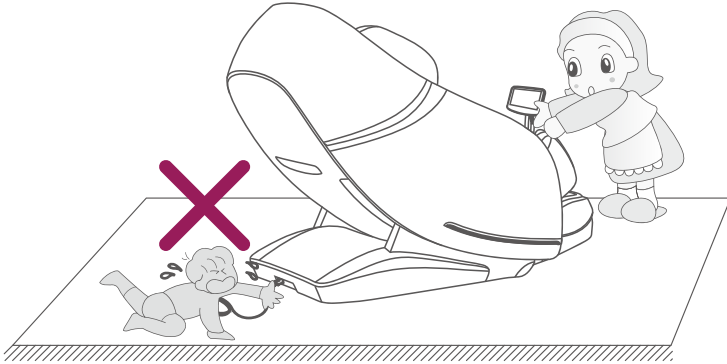
 **Warning**

When switch to “Zero Gravity” mode, please ensure that there are no kids or pets under the calf rest and back area of the massage chair, or else there will be damage to the products as well as personal injury due to the downward movement of the chair.

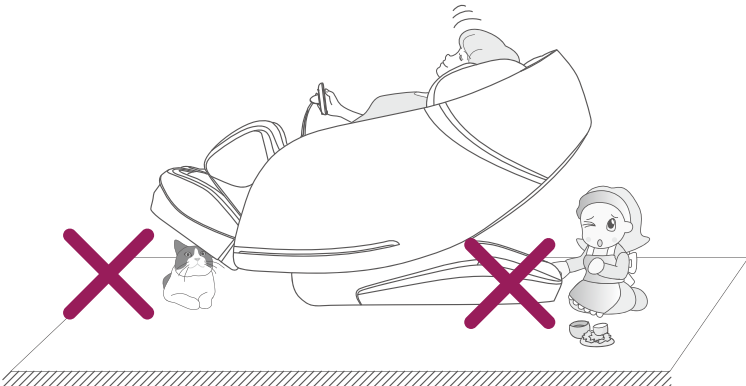

Name and Function of Components

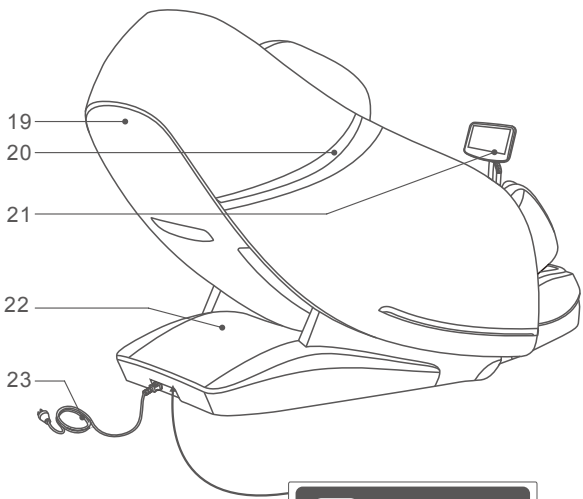
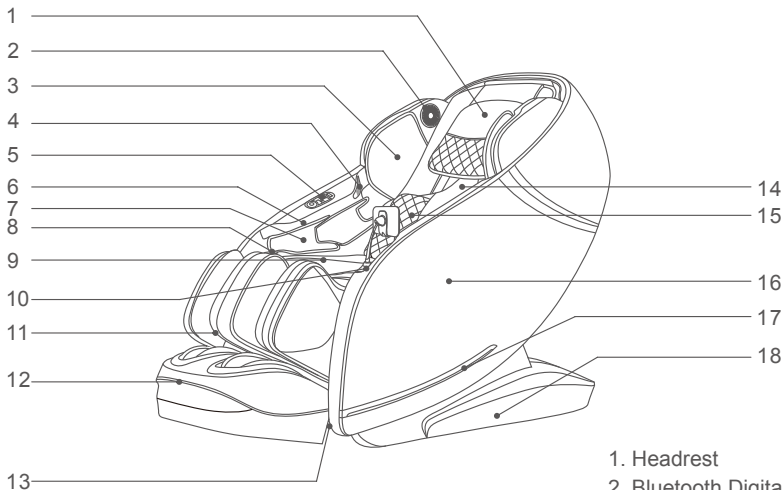

- 1. Headrest
- 2. Bluetooth Digital Speakers
- 3. Upper Arm Airbags
- 4. O2 Ionizer
- 5. Quick Control Panel
- 6. USB Charging Port
- 7. Arm Airbags
- 8. Phone Holder
- 9. Seat Cushion
- 10. Touch Screen Monitor Holder
- 11. Calf Rest
- 12. Footrest
- 13. Front Cover
- 14. Back Cushion
- 15. Back Air Pressure
- 16. Armrest
- 17. LED Atmosphere Light
- 18. Side Cover
- 19. Back Cover
- 20. Armrest Decoration
- 21. Touch Screen Monitor
- 22. PCB Cover
- 23. Power Cord and Plug
- 24. Power Jack
- 25. Power Switch

24 25



Name and Function of Components



Function:

- This product is equipped with a set of silent smart 3D massage heads which move up and down and; front and back.
- Capable of automatically detecting and fine-tuning shoulder position; detecting body curve and shiatsu points to adjust accordingly the movement of the massage heads. This makes the massage experience more personal and scientific.
- Automatic 4 massage settings: Smart AI, Healthcare, Special and Relaxation, encompassing a total of 23 automatic massage programs.
- 3 memory programs: Memory I, Memory II, Memory III.
- Manual Massage Function for the upper body
 - * 5 areas: full back, partial, fixed, upper back and lower back.
 - * 7 massage modes: grasping, rolling, kneading, tapping, shiatsu, kneading and tapping and 3D massage.
 - * Each mode has 5 intensity levels.
 - * For tapping and shiatsu, the width between the massage heads can be adjusted among 5 levels.
- Arm air pressure massage: 8 built-in airbags along forearm area; and 4 along upper arm area. 3 intensity levels available.
- Lower body air pressure massage: 4 built-in airbags along waist area; 4 along leg area; and 16 along foot area. 3 intensity levels available.
- Back heating function: Using carbon fiber as the source of infrared heating.
- “Zero-space” : the forward-sliding design eliminates the large space requirement between the chair and the wall.
- Music player system: 3D digital speakers installed above each armrest. Connect to your smart device and play music via Bluetooth.
- Twisting massage function: using the left-and-right movement of the airbags at waist area to perform and waist-twisting function. Effectively relaxes stiff waist muscle from longtime sitting.
- Quick control panel, with negative ion button, sit-up and recline buttons, zero-gravity button, power button, auto mode button and leg extension button etc., is located on the right armrest.
- Leg rest height adjustment, synchronized seat and leg height adjustment, zero gravity I and zero gravity II.
- Calf kneading function: kneading in opposite direction and air pressure massage function can relax stiff calf muscle from longtime standing. 3 kneading options available.
- Roller massage function: roller massage and gua sha (scraping) for sole.
- Footrest automatic detection function: after setting the height of the calf rest, it will automatically detect the length of the feet and reach the targeted massage areas.
- SL-shaped ultra-long rail perfectly matches the human body shape, ensuring a close-fitting massage from neck to thigh.
- Equipped with a 7” touch screen monitor.
- LED atmosphere lights are installed on the sides of the armrests.
- O2 Ionizers are installed around the arm area.
- USB charging port on the right armrest.
- The upper arm has 2 width levels. Lightly push the armrest to adjust between the 2 levels.
- Automatic reset function: the chair and the massage hands automatically resume to starting position when turned off.

Control Interface

Touch Screen Monitor



*Warning: The real object should be considered as final.

1. Bluetooth power button and display
2. Time adjustment button and display
3. Status bar
4. Shoulder position adjustment button
5. Massage status display
6. Air pressure massage intensity display
7. Massage function button: manual massage, memory program, angle adjustment, settings etc.
8. Power button
9. Auto-massage function button
10. Massage power button
11. 3D massage function button
12. Run/pause button

How to Use

1. Connect to power

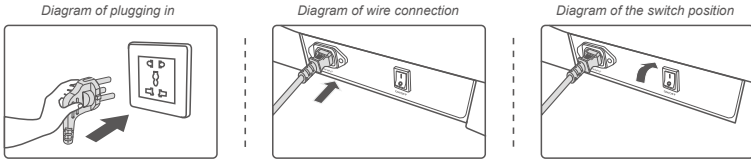

2. Massage Function Operation

1. Begin massage (power button)

- In “standby” mode, there is no access to any massage modes.
- Press the power button to activate the massage program. The monitor will be set to the opening page while the back and calf rest will be set to the default position. Choose your desired massage programs (auto-massage programs or manual settings). The massage chair will automatically shut down if no order received after 5 minutes.

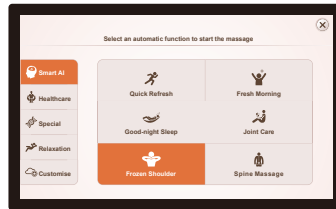

1. Smart AI: Quick Refresh, Fresh Morning, Good-night Sleep, Joint Care, Frozen Shoulder, Spine Massage.
2. Healthcare: Office Regimen, Sport Recovery, Mobile Zombie, Vacation Unwind, Waist Care, Humpback Fix.
3. Special: Pain Relief, Noon Recharge, Deep Massage, Bottom Toning, Circulation Boost, Tiredness Relief.
4. Relaxation: Full-body Stretch, Thai Massage, Chinese Massage, Total Relax, Airbag.

- The back and calf rest will automatically be set in position according to the selected auto-massage program.
- After the angle is set, the chair will automatically detect shoulder position and body shape (note: detecting only shoulder position for “Frozen Shoulder”; full body detection for other auto-massage programs). Press “✕” button to skip the detection process and directly begin the program.

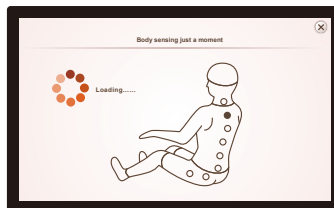
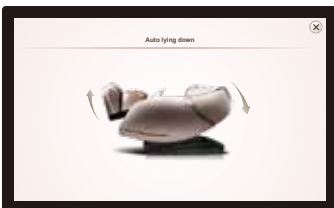

How to Use

- When detection is over, there will be “tik tik” sound. Further finetune the position of the massage hands using the “▲” and “▼” buttons, if needed. There are 11 finetune adjustment levels for shoulder position. If there is no adjustment after 10 seconds, the massage will begin automatically. Or, press the “confirm” button to directly enter the massage program. If the shoulder position is not detected, the massage hands will be set at the default height to begin massage.

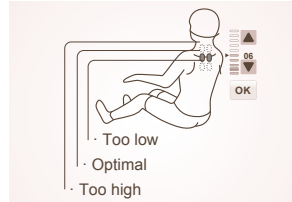
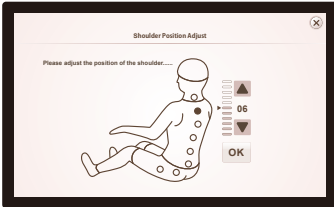

Button	Description
	Mechanical massage hands move upward.
	Mechanical massage hands move downward.

2. Pause Button

- When the massage is in progress, pressing the “■” button will stop all massage functions; and pressing “▶” button again will resume them. If the pause time exceeds 20 minutes, all massage functions will automatically shut down.

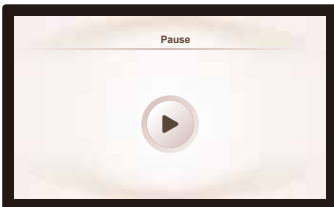

Message Function – Pause

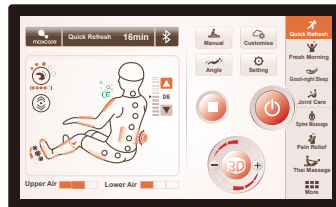

Message is in progress

Button	Description
Pause	Stop all massage functions during run-time.
Run	Resume all massage functions during pause.

How to Use

3. Massage Intensity for Upper Body (3D Button)

- In Massage Information page, pressing the “-” or “+” button will adjust the massage intensity of the mechanical hands for the upper body. There are 5 intensity levels in total.

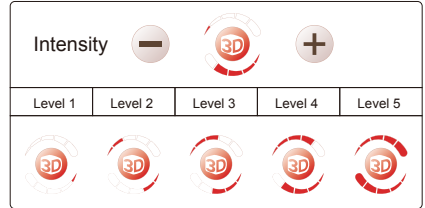
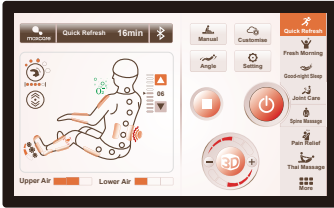

Note : Massage intensity: 3D message refers to the total forward or backward movement of all the mechanical hands. Massage intensity adjustment is applicable to a certain massage area. The massage intensity of each massage point has been checked during body shape detection. Adjust the intensity with this button if needed.

4. Auto-massage Program

There are 4 characterized message settings in the auto-massage program:

- Smart AI (Quick Refresh, Fresh Morning, Good-night Sleep, Joint Care, Frozen Shoulder, Spine Massage)
- Healthcare (Office Regimen, Sport Recovery, Mobile Zombie, Vacation Unwind, Waist Care, Humpback Fix)
- Special (Pain Relief, Noon Recharge, Deep Massage, Bottom Toning, Circulation Boost, Tiredness Relief)
- Relaxation (Full-body Stretch, Thai Massage, Chinese Massage, Total Relax, Airbag)
- A total of 23 auto-massage functions
- Click the auto program button for auto-massage. When an auto-massage function is in progress, speed and width are not adjustable
- Click “More” to see the according auto-massage function

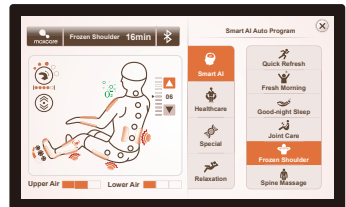
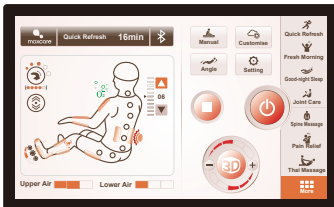

Auto-massage Function

How to Use

Auto Program	Function	Description
Smart AI	Quick Refresh	Alleviate body soreness and tiredness with a back focus. Improve microcirculation for limbs and ease tiredness
	Fresh Morning	Wake body muscle and other mechanism to start the day fresh after a night of sleep
	Good-night Sleep	Through massaging the regimen acupuncture points to nurse and balance the body, improving sleep quality
	Joint Care	Targeting at limbs and joints to carry out massage techniques such as pushing, pulling and stretching. Improve joint strength and quickly relieve soreness of the lower limbs and fatigue of muscle
	Frozen Shoulder	Massage neck and shoulder area with the special designed program, to effectively relieve shoulder pain and promote blood circulation (to brain)
	Spine Massage	Massage every section of the spinal cord to ensure a healthy spine. Help with disc herniation and humpback
Healthcare	Office Regimen	Especially designed for office workers who tend to sit for a long time. Keep the muscle active by massaging and enhance body health
	Sport Recovery	Fast recovery from soreness after workout
	Mobile Zombie	Massage certain acupuncture points to revive neck and shoulder strength
	Vacation Unwind	Special design for people who do not exercise regularly, with a spine focus
	Waist Care	Mainly targeting at waist area to tackle waist pain and improve waist strength
Humpback Fix	Adjust the back and calf rest to form an L-shape (90°). Lock the body with the airbags along the upper arms and perform tui na on the spine from bottom to top	

How to Use

Auto Program	Function	Description
Special	Pain Relief	With reference to the ancient Persian massage, relax the whole body with kneading and tapping
	Noon Recharge	Boost quality of nap and hence raise work efficiency
	Deep Massage	Dredge meridian to encourage body's microcirculation. Enhance immune system
	Bottom Toning	Focus on hip and thigh areas for a shaping effect, help burning excessive body fats
	Circulation Boost	Improve blood circulation, reenergize body and boost the immune system
	Tiredness Relief	Remove blood lactate that is produced after exercise to reenergize body
Relaxation	Full-body Stretch	Increase body flexibility by stretching body muscle
	Thai Massage	Traditional Thai massage consisting of whole-body stretching. Comprehensively erase body tiredness
	Chinese Massage	With reference to the Chinese medical theories, balance the "yin" and "yang" of the body to build better health
	Total Relax	Entirely relieve body muscle and fight off tiredness
	Airbag	Massage the whole body, including arms, with airbags

5. Manual Massage

- Press the "Manual" button to enter the Manual Massage Function page to access different massage functions such as modes, intensity, massage heads width adjustment, back stretch, upper body air massage, lower body air massage, calf kneading, foot roller, negative ion and back thermotherapy.
- Press the "X" button to exit the Manual Massage Function page.

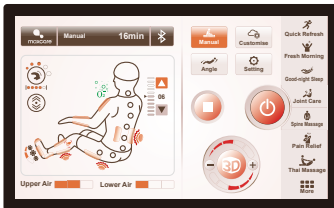

Main - Manual Massage Function

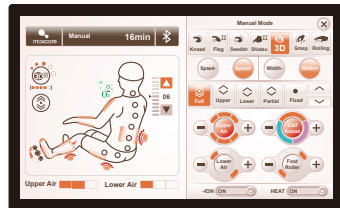

Manual Massage Function

How to Use

5a. Manual – Mode

- In the Manual Massage Function page, you can choose the massage mode, back stretch, the massage speed and the width between massage hands.
- Manual (Mode): kneading, tui na, tapping, kneading and tapping, shiatsu, 3D and grasping.
- For tapping and shiatsu, the width between the massage hands can be adjusted. Adjust the speed of the any massage modes while in motion. Press the “X” button to exit the Manual Massage Function page.

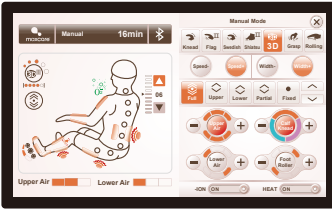

Manual Massage Function – Mode

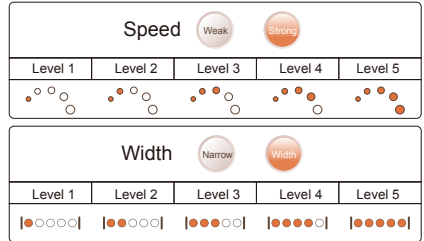

Manual Massage Mode	Description
3D	4 sub-modes, Kneading, Kneading and Tapping, Grasping, Tapping, speed and intensity adjustable.
Kneading	Speed and intensity adjustable
Kneading and Tapping	Speed and intensity adjustable
Grasping	Speed and intensity adjustable
Tapping	2 sub-modes, speed, massage hands width and intensity adjustable
Shiatsu	2 sub-modes, speed, massage hands width and intensity adjustable
Rolling	Speed and intensity adjustable

5b. Manual – Back Stretch

- Manual (Massage Area): full back, partial, fixed, upper back and lower back.
- Press the corresponding stretch buttons to choose different characterized functions. Press the “X” button to exit the Manual Massage Function page.

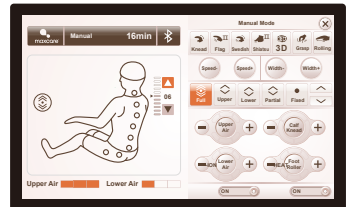

Manual Massage Function – Back Stretch

How to Use

Function	Description
Fixed	Massage a fixed point
Partial	Massage a limited area
Upper Back	Massage the upper back
Lower Back	Massage the lower back
Full Back	Massage the whole back
Up	In “point” or “part” mode, move the massage hands upward
Down	In “point” or “part” mode, move the massage hands downward

5c. Manual – Air Pressure Massage

- Manual (Air Pressure Massage): upper body air pressure massage and lower body air pressure massage.
- Press the corresponding air pressure massage button to turn on/off the function. Press “-” or “+” to adjust the air pressure intensity. Press the “X” button to exit the Manual Massage Function page.

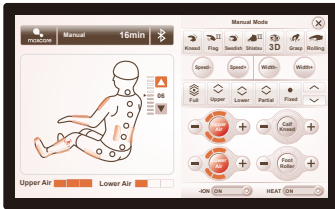

Manual Massage Function – Air Pressure Massage

Intensity		
Level 1	Level 2	Level 3
<p>When the air pressure massage function is on, adjust the pressure intensity among 3 levels.</p>		

Function	Description
Upper Body Air Pressure Massage	Turn on/off the upper body air pressure massage function
Lower Body Air Pressure Massage	Turn on/off the lower body air pressure massage function

How to Use

5d. Manual – Calf Kneading

- Press the “” button to turn on/off the calf kneading function. There are 3 different kneading sub-modes. Press “” or “” to adjust the direction of the kneading motion.
- Press the “” button to exit the Manual Massage Function page.

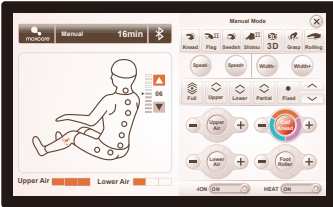

Manual Massage Function – Calf Kneading

Kneading Mode		
Mode I	Mode II	Mode III
Forward	Backward	Forward and backward
After turning on the calf kneading function, adjust the kneading direction.		

Function	Description
	Turn on/off the calf kneading function

5e. Manual – Foot Roller

- Press the “” button to turn on/off the foot roller function. Press “” or “” to adjust the roller speed, which has 3 levels. Press the “” button to exit the Manual Massage Function page.

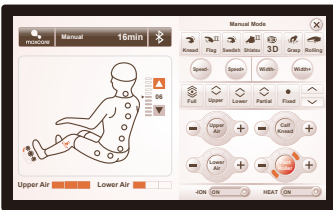

Manual Massage Function – Foot Roller

Speed		
Level 1	Level 2	Level 3

Function	Description
	Turn on/off the foot roller function

How to Use

5f. Manual – Negative Ion

- Press the “ON” button to turn on/off the negative ion function. Press the “X” button to exit the Manual Massage Function page.

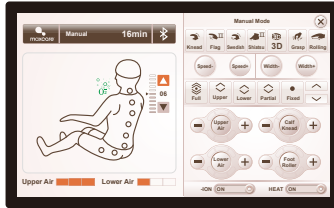

Manual Massage Function – Negative Ion

Function	Description
-ION	Turn on/off the negative ion function

5g. Manual – Back Thermotherapy

- Press the “ON” button to turn on/off the back thermotherapy function, which is the infrared heating function. Heating should be felt after 3 minutes after turning on.
- Press the “X” button to exit the Manual Massage Function page.

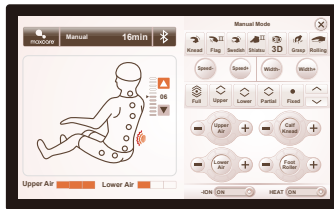

Manual Massage Function – Back Thermotherapy

Function	Description
HEAT	Turn on/off the back thermotherapy function

How to Use

6. Customization

- Press the “” button to enter the Customized Massage Function page to access the memory programs named as Customization I, Customization II and Customization III.
- To save the massage functions or alter saved the massage functions.
- Save: to save the present massage settings, including the massage modes, air pressure, chair angle and all the other massage functions.
- Use: to alter the saved massage settings, including the massage modes, air pressure, chair angle and all the other massage functions.
- Press the “” button to exit the Customized Massage Function page.

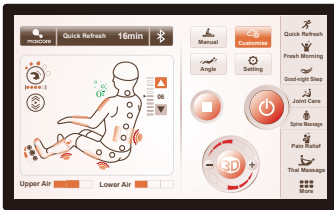

Main - Customized Massage Function

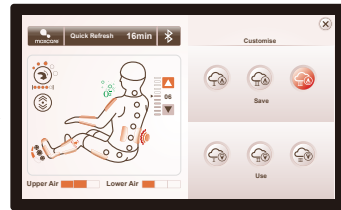

Customized Message - Function

7. Angle Adjustment

- Press the “” button to enter the Angle Adjustment page to access functions including synchronized seat and leg height adjustment, footrest height adjustment, zero-gravity and leg length adjustment.
- Press the “” button to exit the Angle Adjustment page.

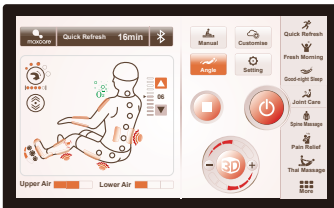



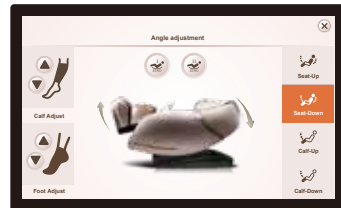

Main - Angle Adjustment Function





Angle Adjustment Function

How to Use



1. Recline angle adjustment

Button	Description
 Seat-Up	Press and hold this button to raise the leg rest. Release the button to stop the motion. When the height is set, the auto-detection function will begin to examine the foot length.
 Seat-Down	Press and hold this button to lower the leg rest. Release the button to stop the motion. When the height is set, the auto-detection function will begin to examine the foot length.
 Seat-Up	Press and hold this button, the back cover will slowly ascend while the leg rest will slowly descend. Release the button to stop the motion. If the massage chair is completely sit-up, it will stop the motion automatically.
 Seat-Down	Press and hold this button, the back cover will slowly descend while the leg rest will slowly ascend. Release the button to stop the motion. If the massage chair is completely laid down, it will stop the motion automatically.

2. Zero-gravity



Button	Description
 ZERO	Zero-gravity I: Automatically set the position of the leg rest and back to Zero-gravity I.
 ZERO	Zero-gravity II: Automatically set the position of the leg rest and back to Zero-gravity II.

3. Leg and foot length adjustment

Button	Description
 Calf Adjust	Up Button: Press and hold this button to manually move the calf rest up until knee height. Release the button to stop the motion.
	Down Button: Press and hold this button to manually move the calf rest down until calf height. Release the button to stop the motion.
 Foot Adjust	Up Button: Press and hold this button to manually shorten the footrest. Release the button to stop the motion.
	Down Button: Press and hold this button to manually lengthen the footrest. Release the button to stop the motion.

How to Use

8. Setting

- Press “  ” button to enter the Setting page to access functions such as brightness adjustment, screen time adjustment, volume adjustment, serial no. and languages.
- Press the “  ” button to exit the Setting page.

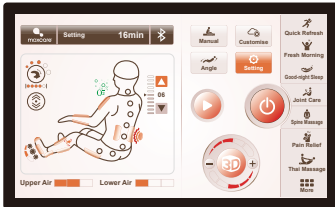

Main - Setting



Setting

1. Brightness

- Adjust brightness of the screen with the slide bar.

2. Auto-Lock

- Choose between 1/3/10/30 minutes for screen-on duration.

3. Sound

- Press the “  X ” button to turn off, or the “  ” button to turn on button sound.



4. Language

- Choose your language.

5. S/N



- Serial No. Display information about present setting.

9. Bluetooth

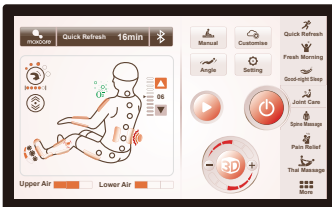
- Press the “  ” button to turn on/off Bluetooth function. “  ” means Bluetooth off; “  ” means Bluetooth on.
- Once connected to the Bluetooth of the massage chair, you can use your smart device to play music through the 3D speakers installed in the chair.



Bluetooth

Bluetooth on/off button	
Bluetooth Off	
Bluetooth On	

Note: To turn on/off Bluetooth, you should return to the main page. Bluetooth function cannot be accessed in Manual Massage Function, Customized Massage Function or Angle Adjustment page.

How to Use

10. Time Adjustment

- Press the “16min” button to set the time of the massage. Each press adds 5 minutes to the current duration of the massage. The total duration cannot exceed 40 minutes. Time will return to its minimum value after exceeding 40 minutes.

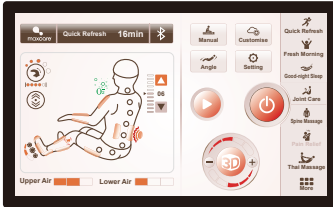

Time Adjustment



Note: To adjust time, you should return to the main page. Time adjustment function cannot be accessed in Manual Massage Function, Customized Massage Function or Angle Adjustment page.

11. Quick Control Panel

Button	Description
	Power Button : Press this button will pasue the massage. Press and hold this button for 3 seconds will turn on/ off the massage. Being on pause for over 20 minutes will automatically terminite all massage functions.
NAI	Negative Ion Button: Press and hold this button to turn on/ off negative ion function.
	Seat-up Button : Press and hold this button to synchronically lift up the back and lower the leg rest. Release the button to stop the motion. When the angle is set, the auto-detection function will begin to examine the foot length.
	Seat-down Button : Press and hold this button to synchronically lower the back and lift up the leg rest. Release the button to stop the motion. When the angle is set, the auto-detection function will begin to examine the foot length.
	Zero-gravity Button : Press the button to set the chair to the Zero-gravity mode. There are 2 Zero-gravity modes in total, press to switch between the 2 modes.
	Up Button : Press and hold this button to manually shorten the footrest. Release the button to stop the motion.
	Down Button : Press and hold this button to manually lengthen the footrest. Release the button to stop the motion.
	Up Button : Press and hold this button to manually move the calf rest up until knee height. Release the button to stop the motion
	Down Button : Press and hold this button to manually move the calf rest down until calf height. Release the button to stop the motion.
AUTO	Auto-mode Button : Press to switch between auto-massage programs.
	USB Port : USB charging port, can be used to charge smart devices (e.g. mobile phones).

How to Use

3. Turn off power, cease massage

- Press the power button when the massage is ongoing will immediately turn off all massage functions. The chair will be set to its starting position.
- When the rated time is up, all massage functions will stop. The chair will however remain in the then position.
- Cut off all power.

1 Switch off the power

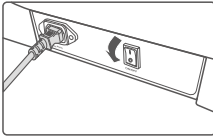

2 Unplug the connection wires

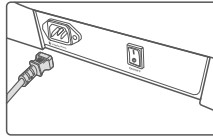

3 Unplug the socket

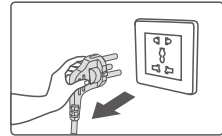

4. Armrest Installation

1. Locate the connection plug corresponding to the armrest from the bottom of the frame and then pass it through from the bottom center of the frame (Pic 1).
2. Connect all the plugs accordingly and properly (with reference to the markings on the actual objects) (Pic 2).

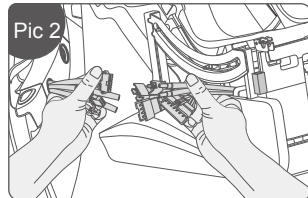
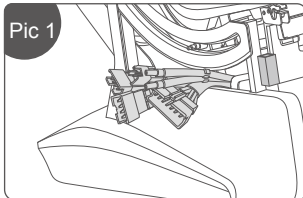

3. Make sure all the connection wires regarding to the armrest from the bottom of the seat are connected, and the air pipe is also firmly attached (Pic 3).
4. After all the related wires are connected, gently tuck them under the seat along the steel pipe in the middle of the frame. Mind the rupture of the air pipe (Pic 4).

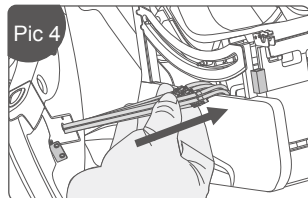
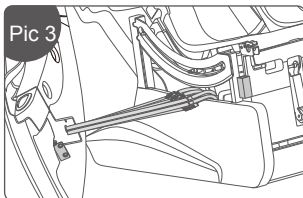

How to Use

5. Hold the tip and the rear end of one armrest with both hands. Insert first the shaft at the rear end of the armrest into the hole on the metal frame of the seat. Uplift the armrest slight to check if the shaft is locked firmly (Pic 5).
6. When the rear end of the armrest is firmly attached, hook the tip of the armrest to the metal frame of the seat and then press it for fastening. Shake the armrest a little to check if the it is installed properly (Pic 6).

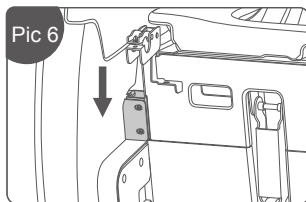
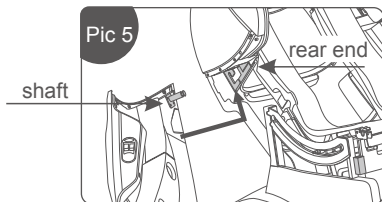

7. Through the mounting holes on the tip of the armrest, screw the two M5x14-12.9 zinc-plated internal hex screws and the 6x12x1.5 zinc-plated flat washer with the provided 4# Allen wrench to affix the armrest to the metal frame of the chair (Pic 7).
8. Screw the rest of the armrest to the chair with five M4x10 screws (Pic 8).

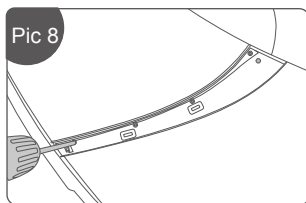
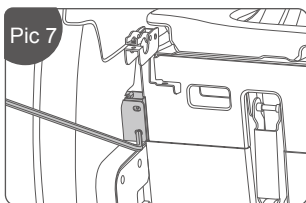

9. Insert the hooks at the bottom of the armrest decoration in the groove under the armrest. Use the two metal locks in the middle to affix to the armrest (Pic 9).
10. From the inner shoulder area of the armrest, use one ST4.2x12 screw to attach firmly the armrest decoration to the armrest. Shake slightly the armrest again to check its stability. Repeat the same steps for the other armrest (Pic 10).

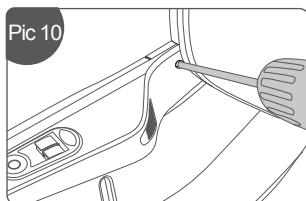
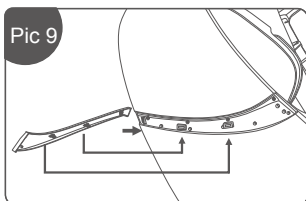

 How to Use

 5. Leg Rest Installation

1. Cut the cable tie on the connection wires and the air pipe (Pic 1).
2. Connect the connection wires and the air pipe from the frame to those from the calf rest properly. And then tuck the wires and the air pipes inside the bottom of the chair. Mind the rupture of the air pipe (Pic 2).

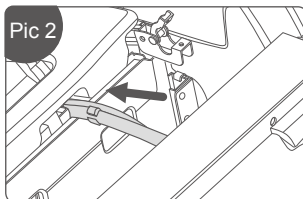
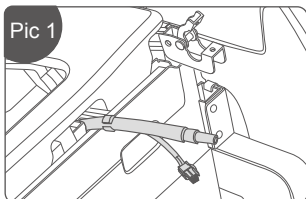

3. Put the inner and outer rotating sleeves on the left and right shafts of the calf rest (note: the thicker side of the cover faces inward) (Pic 3).
4. Open the rotating shaft cover of the chair (Pic 4).

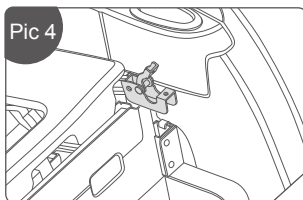
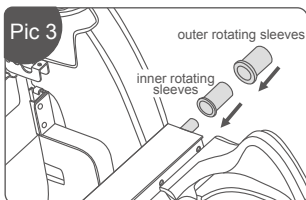

5. Hang the calf rest (by the left and right shafts) on the rotating shaft of the chair (Pic 5).
6. Close the leg rest cover, which should be pressing the tube covers (of the leg rest shaft). Use the provided 4# Allen wrench to screw the two M5x14-12.9 zinc-plated internal hex screws and the 6x12x1.5 zinc-plated flat washer to fasten the cover. The calf rest installation is complete (Pic 6).

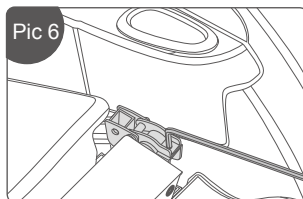
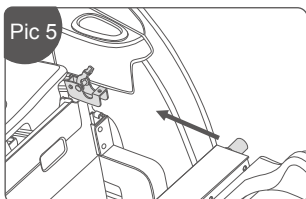

How to Use

7. Clamp the groove at the rear end of the footrest cover is on the pin axis, and then press the tip of the footrest cover until it is parallel to the rotating shaft cover plate, and the convex points at the sides of the footrest should be stuck in the holes at the sides of the footrest hook. The footrest installation is complete (Pic 7).

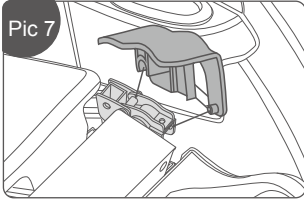

6. Touch Screen Monitor Holder Installation

1. Take out the holder from the accessory bag. Attach the mounting flange of the holder to the armrest (Pic 1).
2. Use two M4 screws to affix the flange tightly on the armrest (Pic 2).

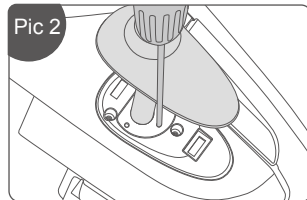
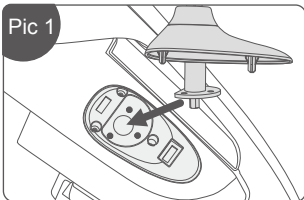

3. Place the two metal plates of the decorative cover on the square frame on the armrest, and then push them into the frame to lock them tightly (Pic 3).
4. When the installation is complete, shake slightly to check if it is stable (Pic 4).

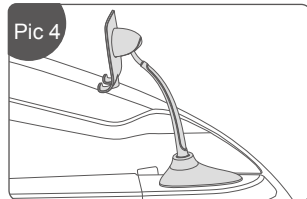
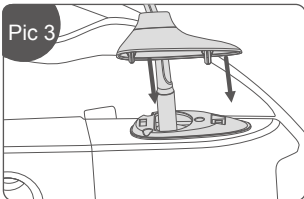

 **How to Use**

 **7. Headrest & Back Cushion Installation and Use**

1. Using the headrest can lessen the massage intensity borne by the neck and shoulders. You may choose to use the headrest according to your own needs (recommended). Back cushion is attached to the back through zipper (1); headrest is attached to the back cushion through Velcro tape (2).

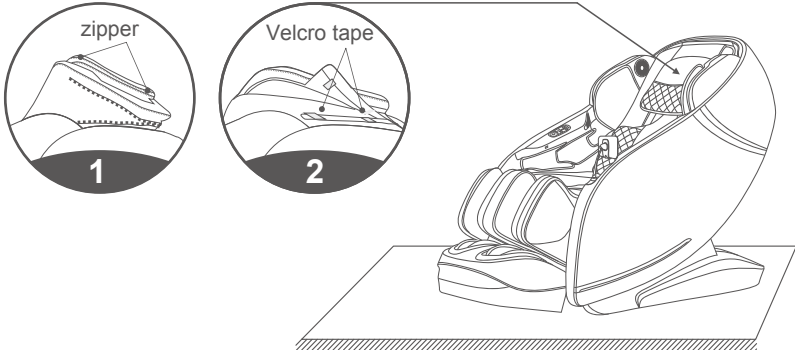

 **8. Floor Protection**

The floor may be damaged due to the heavy pressure from the massage chair. It is advised to place a floor mat or other materials as a buffer to prevent the damage.

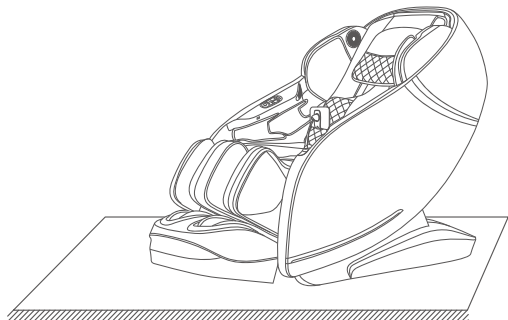

CAUTION: Do not move the chair with its wheels on a bumpy ground or in a narrow space. Two people are required to lift the chair. Hold the leg rest cover and the dent in the back cover while lifting the chair (please do not lift from the armrest).



How to Use



9. Moving the Massage Chair

Before moving the massage chair, make sure no power cords and any cables are on the floor. Two people are required to move the chair, one in front and one at the back. Uplift the chair from the front while press downward at the back. When the focus completely lies on the wheels, push and move the massage chair to a desired destination and slowly erect the chair.

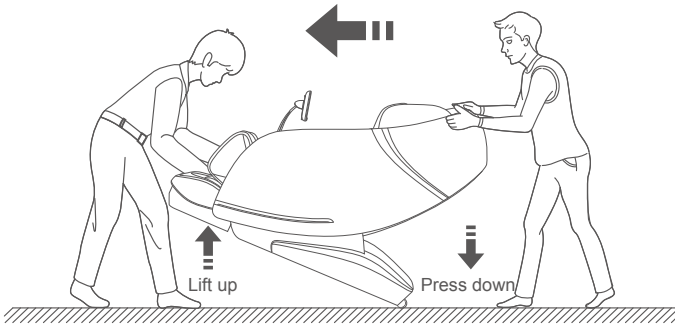

CAUTION: Please make sure all the power is cut off before moving. The power cord and all other cables should be disconnected.



Cleaning and Maintenance

Cleaning

- Before cleaning, please make sure the switch has been turned off and the power plug has been disconnected from the socket.
- Use soft cloths to clean the surface of product and control panel.



CAUTION

- Do not pull the plug from the socket with wet hands.
- Please do not rinse the product. Avoid water/ liquids from getting into the product.
- Do not use corrosive cleaning agents like benzene or thinner to clean the product, otherwise, the color of product will fade, and the internal parts may be corrupted or broken.
- Do not disassemble the product when it is humid. Simply let it dry.

Maintenance

- Make sure that the plug has been disconnected from the socket before maintenance.
- Keep the product clean and away from high-temperature/ humid areas, or any environment with volatile gases.
- If this product is to be left idle for long, properly cover it with a dust cover (self-purchase).



CAUTION

Please keep the product away from direct sunlight, or high temperature, to avoid fading or product damage.

Kind Reminders

* If the product has been used for long, please check the conditions as below:

- Burnt smell.
- Unstable power supply after contact with the power cord.
- Power cord heating up.
- Power cords damage.
- Other abnormalities.



CAUTION

- If above mentioned happens, please stop using the product.
- Switch off the power supply, pull out the plug, and contact us.
- Do not disassemble the product by yourself.



Maintenance and Cleaning of PU Leather

PU leather is made by the coating and drying of polyurethane. Compared with genuine leather, PU leather is more resistant to tear, heat and sunlight. Depending on its nature and chemical substances, however, it should be kept away from any dusty, high/low-temperature, humid environment, under direct sunlight or places with corrosive substance. Otherwise, the leather could tear, quickening aging and hydrolysis.



Cleaning:

1. Please do not use organic reagent or grease solution, especially strong solvent, e.g. alcohol, turpentine and thinner, to clean the surface of the PU leather. Otherwise it will corrode the surface.
2. Please do not use water or washing powder to clean the surface of the PU leather. Otherwise there will be cracks.
3. When cleaning the surface of the PU leather, choose a cleaning agent that has a pH value of between 5~7, no dentifrice, and is harmless to the environment.
4. For dirty PU surface, apply egg whites to the surface using a piece of soft cloth. Avoid using a brush for cleaning.



Maintenance:

1. Keep a good ventilation indoor, overly dry or humid environment can accelerate the aging of leather
2. Please keep the product away from direct sunlight or air vent, otherwise the leather will be hardened. Direct sunlight will also cause fading.
3. People are generally sweater in summer. The holes on the surface of the leather will absorb sweat. While heat and high humidity prompt the chemical reaction between certain substances in sweat and the leather, and hence, causes smell. Please clean the surface more often with a piece of lightly wet cloth.
4. Please do not use alkaline cleaning agents on the leather. It will adversely affect the elasticity of the leather and lead to cracks as a result.

? FAQs and Solutions

No	Symptoms	Possible Causes	Solution
1	"Tik tik" or "tak tak" sound during motion	Normal mechanical sound during motion or the frictional sound between the massage balls and cover	No action needed
2	Cannot be turned on	The adapter has not been well connected	Connect the adapter properly
		The power switch is off	Switch on the power button
		The power plug has not been well connected	Connect the plug to the socket properly
3	Abrupt stop during operation	Power disconnected	Check if the power cord is connected properly
		Rated working time (20 minutes) is up and sleep mode is on	Press the power button to restart
		The machine has been in use for too long, causing overheating protection	Press the power button to restart the machine after cooling down
		The massage hands are stuck	Reduce the pressure on the product

If the abnormal situations persist after taking the above solutions, please contact us.

📄 Technical Specifications

Product Name : Max Generation
Product Model : MAX-76A100
Rated Voltage : 110-120V ~60Hz
 220-240V ~50/60Hz
Rated Power : 220W
Rated Time : 20minutes
Noise : ≤55dB
Product Gross Weight : 159kg
Product Net Weight : 141kg
Compliance : GB4706.1-2005
 GB4706.10-2008

Air Pressure : 0.025-0.03MPa
Negative Ion Concentration : Max. 240000pcs/cm³
Product Size (Erected) : 148x80x118cm
Product Size (Stretched Out) : 180x80x105cm
Back Max. Loading Capacity : 90kg
Leg Rest Max. Loading Capacity : 70kg
Safety Structure : Class I
Material : PU, leather, cotton, wood
Material Description : PVC, PA, steel, electronic parts



商標持有：美斯凱實業有限公司
公司地址：香港北角健康東街39號柯達大廈二期1601室

Trademark holder: Maxcare Industrial Limited
Address: Rm 1601 Kodak House II, 39 Healthy Street East,
North Point, Hong Kong

客戶服務熱線 Customer Service Hotline :
香港 Hong Kong - (852) 2950-9383
中國 China - (86) 400 882-1883



www.maxcare.net
www.maxcareonlineshop.com